

**EXPAND SERIAL COMMAND**

**FUNCTIONAL SPECIFICATIONS**

**PLC-XD2200  
PLC-XD2600**

Ver. 1.00

**SANYO Electric Co., Ltd  
DS Company  
Projector Division**

**- CONTENTS -**

<b>1. Overview .....</b>	<b>8</b>
<b>2. Serial Interface Specification .....</b>	<b>8</b>
<b>2.1 Transfer Specification.....</b>	<b>8</b>
<b>2.2 Connection.....</b>	<b>8</b>
<b>3. Notes for communication.....</b>	<b>9</b>
<b>4. Name Definition.....</b>	<b>9</b>
<b>5. Functional Execution Command Table.....</b>	<b>10</b>
<b>5.1 Image Command Table.....</b>	<b>10</b>
<b>5.2 PC Adjust Control Command Table.....</b>	<b>10</b>
<b>5.3 Input Control Command Table.....</b>	<b>10</b>
<b>5.4 Screen Command Table.....</b>	<b>10</b>
<b>5.5 Lamp Command Table.....</b>	<b>11</b>
<b>5.6 Sound Command Table.....</b>	<b>11</b>
<b>5.7 Setting Command Table.....</b>	<b>11</b>
<b>5.8 Other Command Table.....</b>	<b>11</b>
<b>6. Status Read Command Table.....</b>	<b>12</b>
<b>6.1 Image Status Read Command Table.....</b>	<b>12</b>
<b>6.2 PC Adjust Status Read Command Table.....</b>	<b>12</b>
<b>6.3 Video Status Read Command Table.....</b>	<b>12</b>
<b>6.4 Input Status Read Command Table.....</b>	<b>12</b>
<b>6.5 Screen Status Read Command Table.....</b>	<b>13</b>
<b>6.6 Lamp Status Read Command Table.....</b>	<b>13</b>
<b>6.7 Sound Status Read Command Table.....</b>	<b>13</b>
<b>6.8 Setting Status Read Command Table.....</b>	<b>14</b>
<b>6.9 Other Status Read Command.....</b>	<b>14</b>
<b>7. Error Code Table .....</b>	<b>15</b>
<b>8. Functional Execution Command.....</b>	<b>16</b>
<b>8.1 Format.....</b>	<b>16</b>
<b>8.2 Transfer Example.....</b>	<b>16</b>
<b>8.3 Operation Requirements.....</b>	<b>16</b>
<b>8.4 Image Command.....</b>	<b>17</b>
<b>8.4.1 CF_BRIGHT Command.....</b>	<b>17</b>
<b>8.4.2 CF_CONT Command.....</b>	<b>17</b>
<b>8.4.3 CF_COLOR Command.....</b>	<b>17</b>
<b>8.4.4 CF_TINT Command.....</b>	<b>17</b>
<b>8.4.5 CF_SHARP Command.....</b>	<b>18</b>
<b>8.4.6 CF_GAMMA Command.....</b>	<b>18</b>
<b>8.4.7 CF_WBAL - Command.....</b>	<b>18</b>

8.4.8	CF_COLTEMP Command .....	19
8.4.9	CF_PROGV Command .....	19
8.4.10	CF_NZRED Command .....	19
8.4.11	CF_IMAGE Command .....	20
8.4.12	CF_COLBOARD Command .....	20
8.4.13	CF_IMAGEADJ Command .....	20
8.5	PC Adjust Control Command .....	22
8.5.1	CF_FSYNC Command .....	22
8.5.2	CF_TDOTS Command .....	22
8.5.3	CF_CLAMP Command.....	22
8.5.4	CF_H – POS Command .....	23
8.5.5	CF_V – POS Command .....	23
8.5.6	CF_DDOTS Command.....	23
8.5.7	CF_DLINE Command .....	24
8.5.8	CF_PCSTORE Command.....	24
8.5.9	CF_PCMODEFREE Command.....	24
8.6	Input Control Command.....	25
8.6.1	CF_INPUT Command .....	25
8.6.2	CF_SOURCE Command .....	25
8.6.3	CF_INPUT1 Command .....	26
8.6.4	CF_INPUT2 Command .....	26
8.6.5	CF_INPUT3 Command .....	26
8.6.6	CF_INPUT_%1_%2 Command.....	26
8.6.7	CF_SYSTEM Command .....	27
8.7	Screen Control Command .....	28
8.7.1	CF_SCREEN Command .....	28
8.7.2	CF_DZCENT Command.....	28
8.7.3	CF_KEYSTONE Command .....	29
8.7.4	CF_KYSTNMODE Command .....	29
8.7.5	CF_VSCALE Command.....	29
8.7.6	CF_VPOS Command .....	30
8.7.7	CF_HSCALE Command .....	30
8.7.8	CF_HPOS Command .....	31
8.8	Lamp Command.....	32
8.8.1	CF_LAMPH Command .....	32
8.8.2	CF_LAMPMODE Command .....	32
8.9	Sound Command .....	33
8.9.1	CF_VOLUME Command.....	33
8.9.2	CF_MUTE Command .....	33

<b>8.10</b>	<b>Setting Command</b> .....	<b>34</b>
8.10.1	CF_LANG Command .....	34
8.10.2	CF_MENUPOSITION Command .....	34
8.10.3	CF_INPUTSEARCH Command .....	34
8.10.4	CF_AUTOSETUPPCADJ Command.....	35
8.10.5	CF_AUTOSETUPKEYSTONE Command .....	35
8.10.6	CF_AUTOSETUP Command .....	35
8.10.7	CF_BACKGND Command.....	35
8.10.8	CF_DISP Command.....	36
8.10.9	CF_LOGO Command.....	36
8.10.10	CF_CEIL Command.....	37
8.10.11	CF_REAR Command .....	37
8.10.12	CF_TERMINAL Command .....	37
8.10.13	CF_STANDBYMODE Command.....	37
8.10.14	CF_P-MANE Command .....	38
8.10.15	CF_P-MANETIME Command.....	38
8.10.16	CF_ON-STA Command .....	38
8.10.17	CF_PTIMEMODE Command.....	39
8.10.18	CF_PTIMER Command .....	39
8.10.19	CF_PTIME Command.....	39
8.10.20	CF_RCODE Command.....	39
8.10.21	CF_KEYDIS Command .....	40
8.10.22	CF_PJPINCODE Command.....	40
8.10.23	CF_FANMODE Command.....	40
8.10.24	CF_FANCONTROL Command.....	41
8.10.25	CF_DELAYCTRL Command .....	41
8.10.26	CF_CCAPTIONDISP Command .....	41
8.10.27	CF_CCAPTIONCOLOR Command.....	42
8.10.28	CF_FILTIMER Command .....	42
8.10.29	CF_FILH Command.....	42
8.10.30	CF_FDEFAULT Command .....	42
<b>8.11</b>	<b>Other Command</b> .....	<b>43</b>
8.11.1	CF_KEYENU Command .....	43
8.11.2	CF_MENU Command.....	43
8.11.3	CF_POWER Command.....	43
8.11.4	CF_FREEZE Command .....	44
8.11.5	CF_VMUTE Command.....	44
<b>9.</b>	<b>Status Read Command</b> .....	<b>45</b>
9.1	Format .....	45

<b>9.2</b>	<b>Transfer Example .....</b>	<b>45</b>
<b>9.3</b>	<b>Operation Condition .....</b>	<b>45</b>
<b>9.4</b>	<b>Image Status Read Command .....</b>	<b>46</b>
9.4.1	<b>CR_BRIGHT Command .....</b>	<b>46</b>
9.4.2	<b>CR_CONT Command.....</b>	<b>46</b>
9.4.3	<b>CR_COLOR Command .....</b>	<b>46</b>
9.4.4	<b>CR_TINT Command.....</b>	<b>46</b>
9.4.5	<b>CR_SHARP Command .....</b>	<b>46</b>
9.4.6	<b>CR_GAMMA Command.....</b>	<b>46</b>
9.4.7	<b>CR_WBAL – R Command .....</b>	<b>47</b>
9.4.8	<b>CR_WBAL – G Command .....</b>	<b>47</b>
9.4.9	<b>CR_WBAL – B Command .....</b>	<b>47</b>
9.4.10	<b>CR_COLTEMP Command.....</b>	<b>47</b>
9.4.11	<b>CR_NZRED Command .....</b>	<b>47</b>
9.4.12	<b>CR_PROGV Command.....</b>	<b>48</b>
9.4.13	<b>CR_IMAGE Command .....</b>	<b>48</b>
9.4.14	<b>CR_COLBOARD Command.....</b>	<b>48</b>
9.4.15	<b>CR_IMGGMD Command.....</b>	<b>48</b>
<b>9.5</b>	<b>PC Adjust Status Read Command .....</b>	<b>50</b>
9.5.1	<b>CR_FSYNC Command.....</b>	<b>50</b>
9.5.2	<b>CR_TDOTS Command.....</b>	<b>50</b>
9.5.3	<b>CR_CLAMP Command .....</b>	<b>50</b>
9.5.4	<b>CR_H – POS Command.....</b>	<b>50</b>
9.5.5	<b>CR_V – POS Command.....</b>	<b>50</b>
9.5.6	<b>CR_DDOTS Command .....</b>	<b>51</b>
9.5.7	<b>CR_DLINE Command .....</b>	<b>51</b>
9.5.8	<b>CR_PCSTORE Command .....</b>	<b>51</b>
<b>9.6</b>	<b>Video Status Read Command.....</b>	<b>52</b>
9.6.1	<b>CR_SERSYS Command .....</b>	<b>52</b>
<b>9.7</b>	<b>Input Status Read Command.....</b>	<b>53</b>
9.7.1	<b>CR_INPUT Command .....</b>	<b>53</b>
9.7.2	<b>CR_SOURCE Command .....</b>	<b>53</b>
9.7.3	<b>CR_SRCINP1 Command .....</b>	<b>53</b>
9.7.4	<b>CR_SRCINP2 Command .....</b>	<b>53</b>
9.7.5	<b>CR_SRCINP3 Command.....</b>	<b>53</b>
9.7.6	<b>CR_SYSTEM Command .....</b>	<b>54</b>
9.7.7	<b>CR_SYSLIST Command.....</b>	<b>55</b>
9.7.8	<b>CR_MODELIST Command .....</b>	<b>55</b>
<b>9.8</b>	<b>Screen Status Read Command.....</b>	<b>56</b>

9.8.1	CR_SCREEN Command.....	56
9.8.2	CR_KYSTNMODE Command.....	56
9.8.3	CR_VSCALE Command .....	56
9.8.4	CR_VPOS Command.....	56
9.8.5	CR_HSCALE Command .....	56
9.8.6	CR_HPOS Command.....	57
9.9	Lamp Status Read Command .....	58
9.9.1	CR_LAMPREPL Command .....	58
9.9.2	CR_LAMPH Command .....	58
9.9.3	CR_LAMPCORRESPH Command .....	58
9.9.4	CR_LAMPMODE Command.....	58
9.9.5	CR_LAMPMSTS Command.....	59
9.9.6	CR_PROJH Command .....	59
9.9.7	CR_HMLAMP Command .....	59
9.10	Sound Status Read Command .....	60
9.10.1	CR_VOLUME Command .....	60
9.10.2	CR_MUTE Command.....	60
9.11	Setting Status Read Command .....	61
9.11.1	CR_LANG Command.....	61
9.11.2	CR_INPUTSEARCH Command.....	61
9.11.3	CR_AUTOSSETUPPCADJ Command .....	61
9.11.4	CR_AUTOSSETUPKEYSTONE Command.....	61
9.11.5	CR_BACKGND Command .....	62
9.11.6	CR_DISP Command.....	62
9.11.7	CR_LOGO Command .....	62
9.11.8	CR_CEIL Command.....	62
9.11.9	CR_REAR Command.....	62
9.11.10	CR_TERMINAL Command.....	63
9.11.11	CR_STANDBYMODE Command .....	63
9.11.12	CR_P-MANE Command .....	63
9.11.13	CR_P-MANETIME Command .....	63
9.11.14	CR_ON-STA Command .....	63
9.11.15	CR_PTIMEMODE Command .....	64
9.11.16	CR_PTIMER Command.....	64
9.11.17	CR_PTIME Command .....	64
9.11.18	CR_RCODE Command .....	64
9.11.19	CR_SECURITY Command .....	64
9.11.20	CR_KEYDIS Command .....	65
9.11.21	CR_PJLOCKNOW Command.....	65

9.11.22	CR_PJLOCKMENU Command .....	65
9.11.23	CR_FANMODE Command .....	65
9.11.24	CR_FANCONTROL Command .....	65
9.11.25	CR_DELAYCTRL Command.....	66
9.11.26	CR_FILH Command .....	66
9.11.27	CR_CCAPTIONDISP Command .....	66
9.11.28	CR_CCAPTIONCOLOR Command .....	66
9.11.29	CR_FILREPL Command .....	66
9.11.30	CR_FILTIMER Command.....	67
9.12	Other Status Read Command .....	68
9.12.1	CR_STATUS Command .....	68
9.12.2	CR_SIGNAL Command .....	68
9.12.3	CR_VMUTE Command .....	68
9.12.4	CR_FREEZE Command.....	68
9.12.5	CR_TEMPWARN Command.....	69
9.12.6	CR_TEMP Command.....	70
9.12.7	CR_TEMPFAIL Command.....	71

## 1. Overview

- 1.1 This Functional Specification defines communication functions for PLC-XD2200/2600.
- 1.2 Compatible to Firmware Ver. 1.x of the projector.
- 1.3 Most commands can be used to control projector remotely from PC by RS-232C. Therefore, the commands are defined as Expand Serial Commands.

## 2. Serial Interface Specification

### 2.1 Transfer Specification

Item	Specification
Synchronous System	Asynchronous
Transmission Speed	9600 / 19200
Data Length	8 bit
Parity	N/A
Stop Bit	1
Flow Control	N/A

Note1) Transmission Speed: initial setting value is 19200

Note2) Transmission Speed can be changed in service mode.

### 2.2 Connection

Dedicated serial cable must be used for a connection to a computer and a projector.

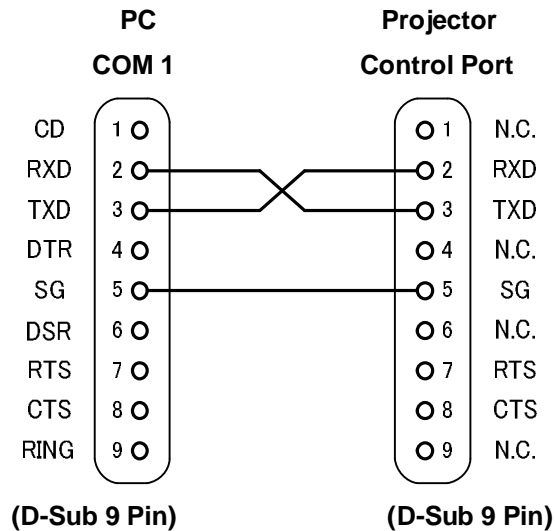

### 3. Notes for communication

1. Expand Serial Command is defined as one command / one line that starts with "C" and ends with carriage return (0x0D)
2. There are two types of commands: Functional Execution Command and Status Read Command.
  - Example of Functional Execution Command: "CF\_BRIGHT\_032"[CR]
  - Example of Status Read Command: "CR\_RIGHT"[CR]

Note) " \_ " means a space

3. When it takes more than one second to receive one command, it is not executed.  
When it takes more than one second to receive carriage return (0X0D) after the projector receives the first data "C", it clears the information of buffer.
4. On command pipelining, wait for the interval of 100ms till sending next command after receiving a response.

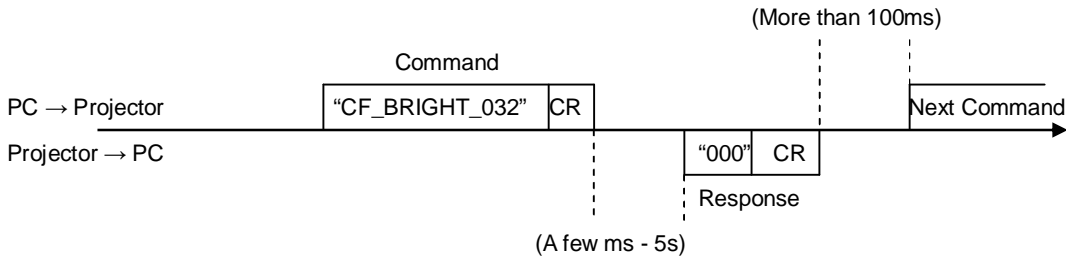

When a computer sends next command before receiving a response, the projector may not operate properly, except when there is no response for more than 5 seconds.

5. It takes about 5 seconds for internal initialization after plugging in AC power. During this time commands cannot be processed. Do not issue any command.

### 4. Name Definition

1. Data from a controller to a projector is represented as COMMAND, and data from a projector to a controller for the incoming command is represented as RESPONSE.
2. [CR] : Carriage Return Code  
Command ends with cartridge return code.  
Response also ends with carriage return code.
3. \_ : Space Code  
A space Code is indicated by (\_).
4. %1 : Parameter in Command  
When there are several parameters, they are defined as %2, %3...
5. %%% : Error code returned from a projector  
Acceptable: "000".  
Unacceptable: See [7. Error Code Table].
6. %a : Parameter in Response Command  
When there are several parameters, they are defined as %b, %c...

## 5. Functional Execution Command Table

### 5.1 Image Command Table

Execute command	Item
CF_BRIGHT_%1[CR]	Set Brightness value
CF_CONT_%1[CR]	Set Contrast value
CF_COLOR_%1[CR]	Set Color value
CF_TINT_%1[CR]	Set Tint value
CF_SHARP_%1[CR]	Set Sharpness value
CF_GAMMA_%1[CR]	Set Gamma value
CF_WBAL-R_%1[CR]	Set White Balance Red value
CF_WBAL-G_%1[CR]	Set White Balance Green value
CF_WBAL-B_%1[CR]	Set White Balance Blue value
CF_COLTEMP_%1[CR]	Set Color Temp. value
CF_PROGV_%1[CR]	Set /Cancel Progressive Scan
CF_NZRED_%1[CR]	Set/Cancel Noise reduction
CF_IMAGE_%1[CR]	Set Image mode
CF_COLBOARD_%1[CR]	Set Colorboard mode
CF_IMAGEADJ_%1[CR]	Reset/Store for Image Adjustment

### 5.2 PC Adjust Control Command Table

Execute command	Item
CF_FSYNC_%1[CR]	Set Fine Sync value
CF_TDOTS_%1[CR]	Set Total Dots value
CF_CLAMP_%1[CR]	Set Clamp Value
CF_H-POS_%1[CR]	Set Horizontal Position value
CF_V-POS_%1[CR]	Set Vertical Position value
CF_DDOTS_%1[CR]	Set Display Dots value
CF_DLINE_%1[CR]	Set Display Line value
CF_PCSTORE_%1[CR]	Store current values of PC Adjust at Mode 1-10
CF_PCMODEFREE_%1[CR]	Release registered values of Mode1-10

### 5.3 Input Control Command Table

Execute command	Item
CF_INPUT_%1[CR]	Select Input
CF_SOURCE_%1[CR]	Select Input Source
CF_INPUT1_%1[CR]	Select computer-1 and set Input selected in %1
CF_INPUT2_%1[CR]	Select computer-2 and set Input selected in %1
CF_INPUT3_%1[CR]	Select Video and set Input selected in %1
CF_INPUT_%1_%2[CR]	Select Input and Source
CF_SYSTEM_%1[CR]	Select System

### 5.4 Screen Command Table

Execute command	Item
CF_SCREEN_%1[CR]	Select Screen size
CF_DZCENT_%1[CR]	Cancel Digital Zoom mode
CF_KEYSTONE_%1[CR]	Set Keystone
CF_KYSTNMODE_%1[CR]	Set Keystone Store mode
CF_VSCALE_%1[CR]	Set value of Vertical scale
CF_VPOS_%1[CR]	Set value of Vertical position
CF_HSCALE_%1[CR]	Set value of Horizontal scale
CF_HPOS_%1[CR]	Set value of Horizontal position

### 5.5 Lamp Command Table

Execute command	Item
CF_LAMPH_%1[CR]	Reset total running time of each lamp
CF_LAMPMODE_%1[CR]	Select Lamp mode

### 5.6 Sound Command Table

Execute command	Item
CF_VOLUME_%1[CR]	Set Volume value
CF_MUTE_%1[CR]	Control ON/OFF of Sound Mute

### 5.7 Setting Command Table

Execute command	Item
CF_LANG_%1[CR]	Select language for OSD
CF_MENUPOSITION_%1[CR]	Move menu position.
CF_INPUTSEARCH_%1[CR]	Set up Input search function
CF_AUTOSETUPPCADJ_%1[CR]	Set Auto PC in Auto Setup
CF_AUTOSETUPKEystone_%1[CR]	Set Auto Keystone in Auto Setup
CF_AUTOSETUP_%1[CR]	Execute Auto Setup
CF_BACKGND_%1[CR]	Set screen mode for the case of no signal
CF_DISP_%1[CR]	Set Display function
CF_LOGO_%1_%2[CR]	Set Logo function
CF_CEIL_%1[CR]	Set Ceiling function
CF_REAR_%1[CR]	Set Rear function
CF_TERMINAL_%1[CR]	Set Terminal function
CF_STANDBYMODE_%1[CR]	Set Standby Mode
CF_P-MANE_%1[CR]	Set Power management function
CF_P-MANETIME_%1[CR]	Set Power management time
CF_ON-STA_%1[CR]	Set Direct on Start function
CF_PTIMERMODE_%1[CR]	Select P-timer mode
CF_PTIMER_%1[CR]	Execute P-timer
CF_PTIME_%1[CR]	Set Countdown timer for P-timer
CF_RCODE_%1[CR]	Select Remote Control Reception Code
CF_KEYDIS_%1[CR]	Disable RC/Projector keys
CF_PJPINCODE_%1[CR]	Input PIN code to release PJ Lock
CF_FANMODE_%1[CR]	Select Fan mode
CF_FANCONTROL_%1[CR]	Select Fan control mode
CF_DELAYCTRL_%1[CR]	Set Video delay control
CF_CCAPTIONDISP_%1[CR]	Set channel of Closed caption
CF_CCAPTIONCOLOR_%1[CR]	Set color of Closed caption
CF_FILTIMER_%1[CR]	Set time when Filter warning OSD is displayed
CF_FILH_%1[CR]	Reset Filter used time
CF_FDEFAULT_%1[CR]	Set the value to Factory Default

### 5.8 Other Command Table

Execute command	Item
CF_KEYEMU_%1[CR]	Behave the same as corresponding key of projector top panel
CF_MENU_%1[CR]	Switch ON/OFF of each Menu.
CF_POWER_%1[CR]	Switch ON/OFF of Power.
CF_FREEZE_%1[CR]	Set Freeze function.
CF_VMUTE_%1[CR]	Set No show function.

## 6. Status Read Command Table

### 6.1 Image Status Read Command Table

Status read command	Item
CR_BRIGHT[CR]	Get Brightness value
CR_CONT[CR]	Get Contrast value
CR_COLOR[CR]	Get Color value
CR_TINT[CR]	Get Tint value
CR_SHARP[CR]	Get Sharpness value
CR_GAMMA[CR]	Get Gamma value
CR_WBAL-R[CR]	White Balance Red value
CR_WBAL-G[CR]	White Balance Green value
CR_WBAL-B[CR]	White Balance Blue value
CR_COLTEMP[CR]	Get setting value of Color temperature
CR_NZRED[CR]	Get setting status of Noise reduction
CR_PROGV[CR]	Get setting status of Progressive scan
CR_IMAGE[CR]	Get Selected Image status
CR_COLBOARD[CR]	Get Selected Colorboard mode
CR_IMGGMD[CR]	Get setting value of Image Gamma

### 6.2 PC Adjust Status Read Command Table

Status read command	Item
CR_FSYNC[CR]	Get setting value of Fine Sync
CR_TDOTS[CR]	Get setting value of Total Dots
CR_CLAMP[CR]	Get setting value of Clamp
CR_H-POS[CR]	Get setting value of Horizontal Position
CR_V-POS[CR]	Get setting value of Vertical Position
CR_DDOTS[CR]	Get setting value of Display Dots
CR_DLINE[CR]	Get setting value of Display Line
CR_PCSTORE[CR]	Get Free or Stored status for PC Adj. mode1-10

### 6.3 Video Status Read Command Table

Status read command	Item
CR_SERSYS[CR]	Get selected current signal. When in Auto mode, it returns a result by Auto detect.

### 6.4 Input Status Read Command Table

Status read command	Item
CR_INPUT[CR]	Get selected Input No.
CR_SOURCE[CR]	Get selected source of currently selected Input
CR_SRCINP1[CR]	Get selected source of Computer 1
CR_SRCINP2[CR]	Get selected source of Computer 2
CR_SRCINP3[CR]	Get selected source of Video
CR_SYSTEM[CR]	Get selected system status in Input mode
CR_SYSLIST[CR]	Get selectable System table
CR_MODELIST[CR]	Get selectable Mode table

**6.5 Screen Status Read Command Table**

Status read command	Item
CR_SCREEN[CR]	Get selected screen size
CR_KYSTNMODE[CR]	Get setting status of Keystone Store mode
CR_VSCALE[CR]	Get setting status of Vertical Scale
CR_VPOS[CR]	Get setting status of Vertical Position
CR_HSCALE[CR]	Get setting status of Horizontal Scale
CR_HPOS[CR]	Get setting status of Horizontal Position

**6.6 Lamp Status Read Command Table**

Status read command	Item
CR_LAMPREPL[CR]	Get the information for Lamp replacement time
CR_LAMPH[CR]	Get lamp total running time
CR_LAMPCORRESPH[CR]	Get corresponding lamp use time
CR_LAMPMODE[CR]	Get Lamp Mode status
CR_LAMPSTS[CR]	Get lamp lighting status
CR_PROJH[CR]	Get projector total running time
CR_HMLAMP[CR]	Get lamp number

**6.7 Sound Status Read Command Table**

Status read command	Item
CR_VOLUME[CR]	Get Volume value
CR_MUTE[CR]	Get Sound Mute setting status

### 6.8 Setting Status Read Command Table

Status read command	Item
CR_LANG[CR]	Get selected language
CR_AUTOSETUPPCADJ	Get setting status of Auto PC in Auto setup
CR_AUTOSETUPKEystone	Get setting status of Keystone in Auto setup
CR_INPUTSEARCH[CR]	Get setting status of Input search
CR_BACKGND[CR]	Get setting status screen mode for the case of no signal
CR_DISP[CR]	Get setting status of Display
CR_LOGO[CR]	Get setting status of Logo
CR_CEIL [CR]	Get setting status of Ceiling
CR_REAR[CR]	Get setting status of Rear
CR_TERMINAL[CR]	Get setting status of Terminal
CR_STANDBYMODE[CR]	Get setting status of Standby Mode
CR_P-MANE[CR]	Get setting status of Power management
CR_P-MANETIME[CR]	Get setting time for Power management
CR_ON-StA[CR]	Get setting status of Direct on
CR_PTIME[CR]	Get selected mode of P-timer
CR_PTIMER[CR]	Get operation status of P-timer
CR_PTIME[CR]	Get setting status of Timer for P-timer
CR_RCODE[CR]	Get selected Remote Control Code
CR_SECURITY[CR]	Get setting status of Security
CR_KEYDIS[CR]	Get RC/KEY disability status
CR_PJLOCKNOW[CR]	Get if PJ Lock is actually in operation
CR_PJLOCKMENU[CR]	Get setting status of PJ Lock on Menu
CR_FANMODE[CR]	Get selected Fan mode
CR_FANCONTROL[CR]	Get selected Fan Control Mode
CR_DELAYCTRL[CR]	Get setting status of Video delay control
CR_CCAPTIONDISP[CR]	Get setting status of channel of Closed caption
CR_CCAPTIONCOLOR[CR]	Get setting status of color of Closed caption
CR_FILH[CR]	Get Filter used time
CR_FILREPL[CR]	Get the information for Filter replacement time
CR_FILTIMER[CR]	Get time when Filter warning OSD is displayed

### 6.9 Other Status Read Command

Status read command	Item
CR_STATUS[CR]	Get setting status of Projector behavior
CR_SIGNAL[CR]	Get Signal Status if there is a signal or not
CR_VMUTE[CR]	Get setting status of No Show
CR_FREEZE[CR]	Get setting status of Freeze
CR_TEMPWARN[CR]	Get if temperature is close to abnormal temperature
CR_TEMP[CR]	Get current temperature status
CR_TEMPFAIL[CR]	Get temperature when sensors detect abnormal temperature

**7. Error Code Table**

Error Code	Contents
?	-When the received data cannot be decoded -Parameter determination error (digit number error, including invalid value, etc.)
101	The function is not available in the selected Mode
102	Selected value is out of range (Not reflected)
103	Command mismatched to Hardware (command for Optional function which is not installed)
201	When reached upper or lower limit of increasing or decreasing data
301	Command cannot be executed during capturing display. Resend the command after a while
302	Command cannot be executed during Auto PC operation. Resend the command after a while
402	Command cannot be executed during PIN code operation. Resend the command after a while.

Note) These error codes are applied to Expand Command, not to Basic Command

## 8. Functional Execution Command

### 8.1 Format

1. PC issues commands in format as below:

**Pattern1** : "CF\_ COMMAND" [CR]

**Pattern2** : "CF\_ COMMAND\_%1 [CR]

CF\_ : Header

COMMAND : Character line

%1 : Parameter (Character line)

\_ : Space (To separate COMMAND and Parameter)

2. The projector decodes the received command and when it is ready to receive the next command, it returns the response.

"000" [CR] : (0x06, 0x0D) When receiving Functional Execution Command

"nnn" [CR] : Except "000", when it is unable to execute command by any specific reason.

See Error Code Table for details

3. When the received data cannot be decoded, the projector returns "?" [CR]

### 8.2 Transfer Example

When setting projector's total dots to 1344 by Expand Serial Command

PC → PJ: "CF\_TDOTS\_1344" [CR]

PC ← PJ: "000"[CR] - - - - - Acceptable

### 8.3 Operation Requirements

- 1) Functional Execution Command is limited when the projector status is as below.

However, Status Read Command is effective even under these conditions.

Projector Status	Available Functional Execution Command
In Standby	C00: POWER ON
Countdown in process	C00: POWER ON (Terminates Countdown) C01: POWER OFF C02: POWER OFF (Terminates Countdown)
Cooling down in process	N/A
Cooling down in process due to Abnormal Temperature	N/A
Abnormal Temperature	N/A
Power Failure (For 60 seconds after Power Failure occurred)	N/A
Power Save / Cooling down in process	N/A
Power Save in process	C00: POWER ON C01: POWER OFF

Note:) When the projector receives the other command in this above status, it returns error code to show the status.

When the projector receives the following functional execution commands, OSD menu is closed except for pop-up menu

- 2) When Eco mode is selected in Standby mode of Setting menu and projector is in Standby, Functional Execution Commands are invalid.

## 8.4 Image Command

### 8.4.1 CF\_BRIGHT Command

Command	"CF_BRIGHT_%1"[CR]	
%1	"000~063" ----- Directly select Brightness setting value "UP" ----- Current Brightness setting value + 1 "DN" ----- Current Brightness setting value - 1	
Details	Set Brightness value of user control Projector does not save the value set with this command so that it resets when projector turning into Standby status or ALL is OFF. (The value is held in Suspend mode.) This command is available in normal Power ON status.	
Response	Acceptable	"000"[CR]
	Unacceptable	"Error Code"[CR]

### 8.4.2 CF\_CONT Command

Command	"CF_CONT_%1"[CR]	
%1	"000~063" ----- Directly select Contrast setting value "UP" ----- Current Contrast setting value + 1 "DN" ----- Current Contrast setting value - 1	
Details	Set Contrast value of user control Projector does not save the value set with this command so that it resets when projector turning into Standby status or ALL is OFF. (The value is held in Suspend mode.) This command is available in normal Power ON status.	
Response	Acceptable	"000"[CR]
	Unacceptable	"Error Code"[CR]

### 8.4.3 CF\_COLOR Command

Command	"CF_COLOR_%1"[CR]	
%1	"000~063" ----- Directly select Color setting value "UP" ----- Current Color setting value + 1 "DN" ----- Current Color setting value - 1	
Details	Set Color value of user control Projector does not save the value set with this command so that it resets when projector turning into Standby status or ALL is OFF. (The value is held in Suspend mode.) This command is available in normal Power ON status.	
Response	Acceptable	"000"[CR]
	Unacceptable	"Error Code"[CR]

### 8.4.4 CF\_TINT Command

Command	"CF_TINT_%1"[CR]	
%1	"000~063" ----- Directly select Tint setting value "UP" ----- Current Tint setting value + 1 "DN" ----- Current Tint setting value - 1	
Details	Set Tint value of user control Projector does not save the value set with this command so that it resets when projector turning into Standby status or ALL is OFF. (The value is held in Suspend mode.) This command is available in normal Power ON status.	
Response	Acceptable	"000"[CR]
	Unacceptable	"Error Code"[CR]

### 8.4.5 CF\_SHARP Command

Command	"CF_SHARP_%1"[CR]	
%1	"000~015" ----- Directly select Sharpness setting value "UP" ----- Current Sharpness setting value + 1 "DN" ----- Current Sharpness setting value - 1	
Details	Set Sharpness value of user control Projector does not save the value set with this command so that it resets when projector turning into Standby status or ALL is OFF. (The value is held in Suspend mode.) This command is available in normal Power ON status.	
Response	Acceptable	"000"[CR]
	Unacceptable	"Error Code"[CR]

### 8.4.6 CF\_GAMMA Command

Command	"CF_GAMMA_%1"[CR]	
%1	"000~015" ----- Directly set Gamma setting value "UP" ----- Current Gamma setting value + 1 "DN" ----- Current Gamma setting value - 1	
Details	Set Gamma value of user control Projector does not save the value set with this command so that it resets when projector turning into Standby status or ALL is OFF. (The value is held in Suspend mode.) This command is available in normal Power ON status.	
Response	Acceptable	"000"[CR]
	Unacceptable	"Error Code"[CR]

### 8.4.7 CF\_WBAL - Command

Command	"CF_WBAL-%1_%2"[CR]	
%1	" R " ----- Red " G " ----- Green " B " ----- Blue	
%2	"000~063" ----- Directly select Color value specified by White Balance%1 "UP" ----- Current Color value set by White Balance%1 + 1 "DN" ----- Current Color value set by White Balance%1 - 1	
Details	Set Color value set by White Balance%1 of user control Projector does not save the value set with this command so that it resets when projector turning into Standby status or ALL is OFF. (The value is held in Suspend mode.) This command is available in normal Power ON status.	
Response	Acceptable	"000"[CR]
	Unacceptable	"Error Code"[CR]

### 8.4.8 CF\_COLTEMP Command

Command	"CF_COLTEMP_%1"[CR]	
%1	"000" ----- Xlow "001" ----- Low "002" ----- Mid "003" ----- High	
Details	Set Color Temperature. (Available only in the normal Power ON status) The value set by this command will not be saved to the projector. Therefore, when turning into Standby-mode or ALL is OFF, the value returns to original setting. (The value is held in Suspend mode.) This command is available in normal Power ON status.	
Response	Acceptable	"000"[CR]
	Unacceptable	"Error Code"[CR]

### 8.4.9 CF\_PROGV Command

Command	"CF_PROGV_%1"[CR]	
%1	"FILM" ----- Select Progressive Mode FILM "L1" ----- Select Progressive Mode L1 "L2" ----- Select Progressive Mode L2 "OFF" ----- Cancel Progressive scan "UP" ----- Switch Progressive mode in positive order OFF → L1 → L2 → FILM → OFF "DN" ----- Switch Progressive mode in negative order OFF → FILM → L2 → L1 → OFF	
Details	Set / cancel Progressive scan Projector does not save the value set with this command so that it resets when projector turning into Standby status or ALL is OFF. (The value is held in Suspend mode.) This command is available in normal Power ON status.	
Response	Acceptable	"000"[CR]
	Unacceptable	"Error Code"[CR]

### 8.4.10 CF\_NZRED Command

Command	"CF_NZRED_%1"[CR]	
%1	"OFF" ----- Cancel Noise Reduction "L1" ----- Noise Reduction for moving image "L2" ----- Noise Reduction for still image "UP" ----- Switch Progressive mode in positive order OFF → L1 → L2 → FILM → OFF "DN" ----- Switch Progressive mode in negative order OFF → FILM → L2 → L1 → OFF	
Details	Noise Reduction based on frame correlation Select L1 or L2 depending on motion detection L2 is more effective in reducing noise than L1, however, L2 can have a blur in moving image Projector does not save the value set with this command so that it resets when projector turning into Standby status or ALL is OFF. (The value is held in Suspend mode.) This command is available in normal Power ON status.	
Response	Acceptable	"000"[CR]
	Unacceptable	"Error Code"[CR]

### 8.4.11 CF\_IMAGE Command

Command	"CF_IMAGE_%1"[CR]	
%1	<p>"DYNAMIC" ----- Dynamic (Fixed value to enable projection with a sharp, powerful picture tone)</p> <p>"STAND" ----- Standard (Image adjust value is set to factory default)</p> <p>"REAL" ----- Real (Fixed value to display graphic image with natural tone)</p> <p>"CINEMA" ----- Cinema (Fixed value to focus on tone reproduction for movie)</p> <p>"BLACKBOARD" – Blackboard (Fixed value to project image onto green-colored blackboard)</p> <p>"COLORBOARD" – Colorboard (Fixed value to project image onto colored board)</p> <p>"CUSTOM1" ----- Image1 (the value set and stored by a user)</p> <p>"CUSTOM2" ----- Image2 (the value set and stored by a user)</p> <p>"CUSTOM3" ----- Image3 (the value set and stored by a user)</p> <p>"CUSTOM4" ----- Image4 (the value set and stored by a user)</p>	
Details	<p>Select Image Mode</p> <p>Parameter "CUSTOM1" to "CUSTOM4" is the same as "Image1" to "Image4" displayed when selecting Image on OSD menu.</p> <p>The value set by this command is stored in EEPROM and its setting is effective even after ALL is OFF.</p> <p>This command is available in normal Power ON status.</p>	
Response	Acceptable	"000"[CR]
	Unacceptable	"Error Code"[CR]

### 8.4.12 CF\_COLBOARD Command

Command	"CF_COLBOARD_%1"[CR]	
%1	<p>"RED" ----- Select Red</p> <p>"BLUE" ----- Select Blue</p> <p>"YELLOW" ----- Select Yellow</p> <p>"GREEN" ----- Select Green</p>	
Details	<p>Select Color of Colorboard mode.</p> <p>Image mode is automatically switched to Colorboard mode by receiving this command.</p> <p>The value set by this command is stored in EEPROM and its setting is effective even after ALL is OFF.</p> <p>This command is available in normal Power ON status.</p>	
Response	Acceptable	"000"[CR]
	Unacceptable	"Error Code"[CR]

### 8.4.13 CF\_IMAGEADJ Command

Command	"CF_IMAGEADJ_%1"[CR]	
%1	<p>"RST" ----- Reset Image adjustment</p> <p>"STR1" ----- Store current Image adjustment to Image 1</p> <p>"STR2" ----- Store current Image adjustment to Image 2</p> <p>"STR3" ----- Store current Image adjustment to Image 3</p> <p>"STR4" ----- Store current Image adjustment to Image 4</p>	
Details	<p>Reset / store Image adjustment.</p> <p>Parameter "STR1" to "STR4" is the same as "Image1" to "Image4" displayed when adjusting Image on OSD menu and selecting "Store"</p> <p>The value stored to "Image1-4" is saved and its setting is effective even after ALL is OFF.</p> <p>This command is available in normal Power ON status.</p>	
Response	Acceptable	"000"[CR]
	Unacceptable	"Error Code"[CR]



## 8.5 PC Adjust Control Command

### 8.5.1 CF\_FSYNC Command

Command	"CF_FSYNC_%1"[CR]	
%1	"0000~0031" ----- Directly select Fine Sync setting value "UP" ----- Current Fine Sync setting value + 1 "DN" ----- Current Fine Sync setting value - 1	
Details	Set Fine Sync value of PC signal Projector does not save the value set with this command so that it resets when projector turning into Standby status or ALL is OFF. This command is available in normal Power ON status.	
Response	Acceptable	"000"[CR]
	Unacceptable	"Error Code"[CR]

### 8.5.2 CF\_TDOTS Command

Command	"CF_TDOTS_%1"[CR]	
%1	"mmmm~nnnn" --- Directly select Total Dots setting value "mmmm" shows minimum value, it is current Display Dots Horizontal value + Position value. "nnnn" shows maximum value, which is not over 140MHz. "UP" ----- Current Total Dots setting value + 1 "DN" ----- Current Total Dots setting value - 1	
Details	Set Total Dots of PC signal Projector does not save the value set with this command so that it resets when projector turning into Standby status or ALL is OFF. This command is available in normal Power ON status.	
Response	Acceptable	"000"[CR]
	Unacceptable	"Error Code"[CR]

### 8.5.3 CF\_CLAMP Command

Command	"CF_CLAMP_%1"[CR]	
%1	"mmmm~nnnn" ---- Directly select Clamp setting value "mmmm" shows minimum value, fixed-value "0001". "nnnn" shows maximum value: it depends on input signal. "UP" ----- Current Clamp setting value + 1 "DN" ----- Current Clamp setting value - 1	
Details	Set Clamp value of PC signal Projector does not save the value set with this command so that it resets when projector turning into Standby status or ALL is OFF. This command is available in normal Power ON status.	
Response	Acceptable	"000"[CR]
	Unacceptable	"Error Code"[CR]

### 8.5.4 CF\_H – POS Command

Command	"CF_H-POS_%1"[CR]	
%1	"0000~nnnn" --- Directly select Horizontal Position setting value "nnnn" shows maximum value, it is current Total Dots value - Display Dots value "UP" ----- Current Horizontal Position setting value + 1 "DN" ----- Current Horizontal Position setting value - 1	
Details	Set Horizontal Position value of PC signal. Projector does not save the value set with this command so that it resets when projector turning into Standby status or ALL is OFF. This command is available in normal Power ON status.	
Response	Acceptable	"000"[CR]
	Unacceptable	"Error Code"[CR]

### 8.5.5 CF\_V – POS Command

Command	"CF_V-POS_%1"[CR]	
%1	"0000~nnnn" --- Directly select Vertical Position setting value "nnnn" shows maximum value, it is current Total Line value - Display Line value "UP" ----- Current Vertical Position setting value + 1 "DN" ----- Current Vertical Position setting value - 1	
Details	Set Vertical Position value of PC signal Projector does not save the value set with this command so that it resets when projector turning into Standby status or ALL is OFF. This command is available in normal Power ON status.	
Response	Acceptable	"000"[CR]
	Unacceptable	"Error Code"[CR]

### 8.5.6 CF\_DDOTS Command

Command	"CF_DDOTS_%1"[CR]	
%1	"0256~"nnnn" --- Directly select Display Dots setting value "nnnn" shows maximum value, it is current Total Dots value - Horizontal Position value Even number is available and when odd number is set, it is rounded out. "UP" ----- Current Display Dots setting value + 2 "DN" ----- Current Display Dots setting value - 2	
Details	Set Display Dots value of PC signal Projector does not save the value set with this command so that it resets when projector turning into Standby status or ALL is OFF. This command is available in normal Power ON status.	
Response	Acceptable	"000"[CR]
	Unacceptable	"Error Code"[CR]

### 8.5.7 CF\_DLINE Command

Command	"CF_DLINE_%1"[CR]	
%1	<p>"0100"~"nnnn" --- Directly select Display Line setting value                      "nnnn" shows maximum value, it is current Total Line value – Vertical Position value</p> <p>"UP" ----- Current Display Line setting value + 1                      "DN" ----- Current Display Line setting value – 1</p>	
Details	<p>Set Display Line value of PC signal                      Projector does not save the value set with this command so that it resets when projector turning into Standby status or ALL is OFF.                      This command is available in normal Power ON status.</p>	
Response	Acceptable	"000"[CR]
	Unacceptable	"Error Code"[CR]

### 8.5.8 CF\_PCSTORE Command

Command	"CF_PCSTORE_%1"[CR]	
%1	<p>"MODE1" ---- Store current PC Adjust status to Mode1                      "MODE2" ---- Store current PC Adjust status to Mode2                      "MODE3" ---- Store current PC Adjust status to Mode3                      "MODE4" ---- Store current PC Adjust status to Mode4                      "MODE5" ---- Store current PC Adjust status to Mode5                      "MODE6" ---- Store current PC Adjust status to Mode6                      "MODE7" ---- Store current PC Adjust status to Mode7                      "MODE8" ---- Store current PC Adjust status to Mode8                      "MODE9" ---- Store current PC Adjust status to Mode9                      "MODE10" --- Store current PC Adjust status to Mode10</p>	
Details	<p>Store current PC Adjust status (each parameter status such as Total dots) to Mode1-Mode10. This command operates the same way as storing to Mode1-Mode10 in PC Adjust MENU.                      This command is available in normal Power ON status.</p>	
Response	Acceptable	"000"[CR]
	Unacceptable	"Error Code"[CR]

### 8.5.9 CF\_PCMODEFREE Command

Command	"CF_PCMODEFREE_%1"[CR]	
%1	<p>"MODE1" ---- Set Mode1 to Free status                      "MODE2" ---- Set Mode2 to Free status                      "MODE3" ---- Set Mode3 to Free status                      "MODE4" ---- Set Mode4 to Free status                      "MODE5" ---- Set Mode5 to Free status                      "MODE6" ---- Set Mode6 to Free status                      "MODE7" ---- Set Mode7 to Free status                      "MODE8" ---- Set Mode8 to Free status                      "MODE9" ---- Set Mode9 to Free status                      "MODE10" --- Set Mode10 to Free status</p>	
Details	<p>Delete the registered data in Mode1-Mode10 and turns it to Free status.                      This command operates the same as turning Mode1-Mode10 to Free in PC Adjust Menu.                      This command is available in normal Power ON status.</p>	
Response	Acceptable	"000"[CR]
	Unacceptable	"Error Code"[CR]

## 8.6 Input Control Command

### 8.6.1 CF\_INPUT Command

Command	"CF_INPUT_%1"[CR]	
%1	<p>"COMPUTER1" ----- Select Computer1 Input                  "COMPUTER2" ----- Select Computer2 Input                  "VIDEO" ----- Select Video Input                  "UP" ----- Switch Input setting forward                  When Computer 2 is selected in Terminal menu:                  Computer1 → Computer2 → Video →Computer1 → ...</p> <p>When Monitor out is selected in Terminal menu:                  Computer1 → Video →Computer1 → ...</p> <p>"DN" -----Switch Input setting backward                  When Computer 2 is selected in Terminal menu:                  Video → Computer2 →Computer1→....</p> <p>When Monitor out is selected in Terminal menu:                  Video →Computer1→....</p>	
Details	<p>Select Input                  The same operation as "INPUT" button of the projector and Remote Control.                  This command is available in normal Power ON status.</p> <p>Projector returns "101" by selecting Computer 2 while Monitor out is selected in Terminal menu.</p>	
Response	Acceptable	"000"[CR]
	Unacceptable	"Error Code"[CR]

### 8.6.2 CF\_SOURCE Command

Command	"CF_SOURCE_%1"[CR]	
%1	Input is Computer 1	<p>"ANALOG" ----- Select Analog Input                  "YPBPR" ----- Select Component Input                  "S - VIDEO" ----- Select S-Video Input                  "SCART" ----- Select Scart Input                  "UP" ----- Switch Input as follows                  Analog →YPBPR →S-Video →Scart →...</p> <p>"DN" ----- Switch Input as follows                  Scart →S-Video →YPBPR →Analog →...</p>
	Input is Computer 2	<p>"ANALOG" ----- Select Analog Input                  "UP"                  "DN"                  Although no operation is executed, projector accepts parameter "UP" /"DN"</p>
	Input is Video	<p>"VIDEO" ----- Select Composite Video Input                  "UP"                  "DN"                  Although no operation is executed, projector accepts parameter "UP" /"DN"</p>
Details	<p>Select Source of currently selected Input                  When Input specified by %1 is inappropriate for selected Input, the projector returns "101" and the command is not executed.                  This command is available in normal Power ON status.</p>	
Response	Acceptable	"000"[CR]
	Unacceptable	"Error Code"[CR]

### 8.6.3 CF\_INPUT1 Command

Command	"CF_INPUT1_%1_"[CR]	
%1	"ANALOG" ----- Select Analog RGB Input "YPBPR" ----- Select Component "S - VIDEO" ----- Select S-Video Input "SCART" ----- Select SCART	
Details	Select Computer 1 input and source specified by %1 at the same time. This command is available in normal Power ON status.	
Response	Acceptable	"000"[CR]
	Unacceptable	"Error Code"[CR]

### 8.6.4 CF\_INPUT2 Command

Command	"CF_INPUT2_%1_"[CR]	
%1	"ANALOG" ----- Select Analog RGB Input	
Details	Select Computer 2 input and source specified by %1 at the same time. This command is available in normal Power ON status.  Projector returns "101" by selecting Computer 2 while Monitor out is selected in Terminal menu.	
Response	Acceptable	"000"[CR]
	Unacceptable	"Error Code"[CR]

### 8.6.5 CF\_INPUT3 Command

Command	"CF_INPUT3_%1_"[CR]	
%1	"VIDEO" ----- Select Composite video Input	
Details	Select Video input. This command is available in normal Power ON status.	
Response	Acceptable	"000"[CR]
	Unacceptable	"Error Code"[CR]

### 8.6.6 CF\_INPUT\_%1\_%2 Command

Command	"CF_INPUT_%1_%2"[CR]	
%1	"COMPUTER1" ----- Select Computer1 Input "COMPUTER2" ----- Select Computer2 Input "VIDEO" ----- Select Analog Input "S-VIDEO" ----- Select S-video Input	
%2	When %1 is COMPUTER1 "ANALOG" -----Select Analog RGB Input "YPBPR" ----- Select Component "S-VIDEO" ----- Select S-Video Input "SCART" ----- Select SCART When %1 is COMPUTER2 "ANALOG" ----- Select Analog RGB Input When %1 is VIDEO "VIDEO" ----- Select Video Input	
Details	Select Input specified by %1 and also Source specified by %2 at once This command is available in normal Power ON status.  Projector returns "101" by selecting Computer 2 while Monitor out is selected in Terminal menu.	
Response	Acceptable	"000"[CR]

	Unacceptable	"Error Code"[CR]
--	--------------	------------------

**8.6.7 CF\_SYSTEM Command**

Command	"CF_SYSTEM_%1"[CR]	
%1	Input is Computer	"VGA1" ----- Select VGA1 : "XGA1" ----- Select XGA1 : "WXGA3" ----- Select WXGA3 "1080I" ----- Select 1080I "1035I" ----- Select 1035I "720P" ----- Select 720P "575P" ----- Select 575P "480P" ----- Select 480P "575I" ----- Select 575I "480I" ----- Select 480I "MODE1"~ "MODE10"----- Select Mode 1~Mode 10
	Input is Video	"AUTO" ----- Select System "Auto" "NTSC" ----- Select NTSC "NTSC443" ----- Select NTSC4.43 "PAL" ----- Select PAL "SECAM" ----- Select SECAM "PAL-M" ----- Select PAL-M "PAL-N" ----- Select PAL-N "1080I" ----- Select 1080i "1035I" ----- Select 1035i "720P" ----- Select 720p "575P" ----- Select 575p "480P" ----- Select 480p "575I" ----- Select 575i "480I" ----- Select 480i
Details	Select System of currently selected Input When Input specified by %1 is inappropriate for selected Input, the projector returns "101"[CR] and the command is not executed This command is available in normal Power ON status.  Note1) "NTSC" / "NTSC4.43" / "PAL" / "SECAM" / "PAL-M" / "PAL-N" is available only when Input is VIDEO / S-VIDEO Note2) "1080I" / "1035I" / "720P" / "575P" / "480P" / "575I" / "480I" is available only when Input is Y / Pb/Cb / Pr/Cr	
Response	Acceptable	"000"[CR]
	Unacceptable	"Error Code"[CR]

## 8.7 Screen Control Command

### 8.7.1 CF\_SCREEN Command

Command	"CF_SCREEN_%1"[CR]	
%1	Input is Computer	<p>"NORMAL" ----- Select Normal size                      "TRUE" ----- Select True size                      "WIDE" ----- Select Wide size                      "FULL" ----- Select Full screen size                      "CUSTOM" ----- Select Custom size                      "DZOOM_UP" ----- Expand image size with Digital Zoom                      "DZOOM_DN" ----- Reduce image size with Digital Zoom                      "UP" ----- Switch selectable screen size in positive order                      (Normal → True → Wide → Full → Custom → Normal)                      "DN" ----- Switch selectable screen size in negative order                      (Normal → Custom → Full → Wide → True → Normal)</p>
	Input is Video	<p>"NORMAL" ----- Select Normal mode                      "WIDE" ----- Select Wide mode                      "CUSTOM" ----- Select Custom size                      "UP" ----- Switch selectable screen size in positive order                      (Normal → Wide → Custom → Normal)                      "DN" ----- Switch selectable screen size in negative order                      (Normal → Custom → Wide → Normal)</p>
Details	<p>Select image size on screen.                      When Input specified by %1 is inappropriate for selected Input, the projector returns "101" [CR] and the command is not executed.                      "DZOOM UP" and "DZOOM DN" start effecting from the first command.                      This command is available in normal Power ON status.</p> <p>(Note) When Input is computer and AV sorts signals (480i / 575i...etc) are entered, the signal recognized as Video Input.</p>	
Response	Acceptable	"000"[CR]
	Unacceptable	"Error Code"[CR]

### 8.7.2 CF\_DZCENT Command

Command	"CF_DZCENT_%1"[CR]	
%1	"CENT" ---- Cancel Digital Zoom (CENT: "CENTER")	
Details	<p>Cancel Digital Zoom                      When image is expanded or shrunk, reset its value.                      This command is available in normal Power ON status and when Input is Computer.</p>	
Response	Acceptable	"000"[CR]
	Unacceptable	"Error Code"[CR]

### 8.7.3 CF\_KEYSTONE Command

Command	"CF_KEYSTONE_%1"[CR]	
%1	"UP" ----- Correct Keystone distortion to reduce upper part of image "FUP" ----- Correct Keystone distortion to reduce upper part by 2steps "DN" ----- Correct Keystone distortion to reduce lower part of image "FDN" ----- Correct Keystone distortion to reduce lower part by 2steps "RST" ----- Reset Keystone	
Details	Change Keystone distortion correction This command is available in normal Power ON status.	
Response	Acceptable	"000"[CR]
	Unacceptable	"Error Code"[CR] "201"[CR] ----When reaching the Keystone correction limit or reaching 1 step to correction limit and "FDN"/"FUP" is received. (The command is not executed)

### 8.7.4 CF\_KYSTNMODE Command

Command	"CF_KYSTNMODE_%1"[CR]	
%1	"STR" ----- Set Keystone store mode to Store "RST" ----- Set Keystone store mode to Reset	
Details	Set Keystone store mode This command is available in normal Power ON status.	
Response	Acceptable	"000"[CR]
	Unacceptable	"Error Code"[CR]

### 8.7.5 CF\_VSCALE Command

Command	"CF_VSCALE_%1"[CR]	
%1	"032" ----- +32 "031" ----- +31 : "002" ----- +2 "001" ----- +1 "000" ----- ±0 "-01" ----- -1 "-02" ----- -2 : "-31" ----- -31 "-32" ----- -32 "UP" ----- Vertical Scale setting value + 1 "DN" ----- Vertical Scale setting value - 1	
Details	Set Vertical Scale This command is available in normal Power ON status. Note1) When Screen setting is not in Custom mode, projector changes image mode into Custom by receiving this command. Note2) When there is no signal detected, projector returns 101 and the command does not execute.	
Response	Acceptable	"000"[CR]
	Unacceptable	"Error Code"[CR]

### 8.7.6 CF\_VPOS Command

Command	"CF_VPOS_%1"[CR]	
%1	"015" ----- +15 "014" ----- +14 : "002" ----- +2 "001" ----- +1 "000" ----- ±0 "-01" ----- -1 "-02" ----- -2 : "-14" ----- -14 "-15" ----- -15 "UP" ----- Vertical Position setting value + 1 "DN" ----- Vertical Position setting value - 1	
Details	Set Vertical Position This command is available in normal Power ON status.  Note1) When Screen setting is not in Custom mode, projector changes image mode into Custom by receiving this command. Note2) When there is no signal detected, projector returns 101 and the command does not execute..	
Response	Acceptable	"000"[CR]
	Unacceptable	"Error Code"[CR]

### 8.7.7 CF\_HSCALE Command

Command	"CF_HSCALE_%1"[CR]	
%1	"032" ----- +32 "031" ----- +31 : "002" ----- +2 "001" ----- +1 "000" ----- ±0 "-01" ----- -1 "-02" ----- -2 : "-31" ----- -31 "-32" ----- -32 "UP" ----- Horizontal Scale setting value + 1 "DN" ----- Horizontal Scale setting value - 1	
Details	Set Horizontal Scale This command is available in normal Power ON status.  Note1) When Screen setting is not in Custom mode, projector changes image mode into Custom by receiving this command. Note2) When there is no signal detected, projector returns 101 and the command does not execute.	
Response	Acceptable	"000"[CR]
	Unacceptable	"Error Code"[CR]

### 8.7.8 CF\_HPOS Command

Command	"CF_HPOS_%1"[CR]	
%1	"015" ----- +15 "014" ----- +14 : "002" ----- +2 "001" ----- +1 "000" ----- ±0 "-01" ----- -1 "-02" ----- -2 : "-14" ----- -14 "-15" ----- -15 "UP" ----- Horizontal Position setting value + 1 "DN" ----- Horizontal Position setting value - 1	
Details	Set Horizontal Position This command is available in normal Power ON status.  Note1) When Screen setting is not in Custom mode, projector changes image mode into Custom by receiving this command. Note2) When there is no signal detected, projector returns 101 and the command does not execute.	
Response	Acceptable	"000"[CR]
	Unacceptable	"Error Code"[CR]



## 8.9 Sound Command

### 8.9.1 CF\_VOLUME Command

Command	"CF_VOLUME_%1"[CR]	
%1	"000-031" ----- Directly select Volume setting value "UP" ----- Current Volume setting value +1 "DN" ----- Current Volume setting value -1	
Details	Control Volume value The same operation of Volume Up/Down as projector and RC, and directly select Volume setting value. When setting Volume value, the Sound Mute ON status is canceled just like RC operation. The value set by this command is stored in Projector. This command is available in normal Power ON status.	
Response	Acceptable	"000"[CR]
	Unacceptable	"Error Code"[CR]

### 8.9.2 CF\_MUTE Command

Command	"CF_MUTE_%1"[CR]	
%1	"ON" ----- Set Sound Mute to ON "OFF" ----- Set Sound Mute to OFF	
Details	Control Sound Mute ON/OFF This command is available in normal Power ON status.	
Response	Acceptable	"000"[CR]
	Unacceptable	"Error Code"[CR]

## 8.10 Setting Command

### 8.10.1 CF\_LANG Command

Command	"CF_LANG_%1"[CR]	
%1	"ENG" ----- Select English "DEU" ----- Select German "FRA" ----- Select French "ITA" ----- Select Italian "ESP" ----- Select Spanish "POR" ----- Select Portuguese "NED" ----- Select Dutch "SVE" ----- Select Swedish "RUS" ----- Select Russian "CHI" ----- Select Chinese "KOR" ----- Select Korean "JPN" ----- Select Japanese "FIN" ----- Select Finnish "POL" ----- Select Polish "HUN" ----- Select Hungarian "ROM" ----- Select Romanian "THA" ----- Select Thai "TUR" ----- Select Turkish "KAZ" ----- Select Kazakh "VIE" ----- Select Vietnamese	
Details	Set language for OSD The language set by this command is stored in EEPROM and its setting is effective after ALL is OFF. This command is available in normal Power ON status.	
Response	Acceptable	"000"[CR]
	Unacceptable	"Error Code"[CR]

### 8.10.2 CF\_MENUPOSITION Command

Command	"CF_MENUPOSITION_%1"[CR]	
%1	"SET" ----- Move the menu display to next position	
Details	Change the menu position This command is available in normal Power ON status. The language set by this command is stored in EEPROM and its setting is effective after ALL is OFF. Position: top left - top right – center – bottom left-bottom right – top left...	
Response	Acceptable	"000"[CR]
	Unacceptable	"Error Code"[CR]

### 8.10.3 CF\_INPUTSEARCH Command

Command	"CF_INPUTSEARCH_%1"[CR]	
%1	"OFF" ----- Set Input search operation to OFF "ON1" ----- Set Input search operation to On1 "ON2" ----- Set Input search operation to On2	
Details	Set Input search operation mode. The status set by this command is stored in EEPROM and its setting is effective after ALL is OFF This command is available in normal Power ON status. Note) It is unable to set Keystone, PC ADJ. and Input search to OFF at once. e.g. If projector receives Input search OFF command while Auto PC ADJ. and Keystone are OFF, it returns error code "101"..	
Response	Acceptable	"000"[CR]

	Unacceptable	"Error Code"[CR]
--	--------------	------------------

#### 8.10.4 CF\_AUTOSETUPPCADJ Command

Command	"CF_AUTOSETUPPCADJ_%1"[CR]	
%1	"ON" ----- Set Auto PC ADJ. function to ON "OFF" ----- Set Auto PC ADJ. function to OFF	
Details	Set/Cancel Auto PC adj. function This command is available in normal Power ON status. Note) It is unable to set Keystone, PC ADJ. and Input search to OFF at once. e.g. If projector receives Auto PC ADJ. OFF command while Keystone and Input search are OFF, it returns error code "101".	
Response	Acceptable	"000"[CR]
	Unacceptable	"Error Code"[CR]

#### 8.10.5 CF\_AUTOSETUPKEYSTONE Command

Command	"CF_AUTOSETUPKEYSTONE_%1"[CR]	
%1	"AUTO" ----- Set Auto Keystone function to Auto "MANUAL" ----- Set Auto Keystone function to Manual "OFF" ----- Set Auto Keystone function to OFF	
Details	Set Keystone function of Auto setup This command is available in normal Power ON status. Note) It is unable to set Keystone, PC ADJ. and Input search to OFF at once. e.g. If projector receives Keystone OFF command while Auto PC ADJ. and Input search are OFF, it returns error code "101"..	
Response	Acceptable	"000"[CR]
	Unacceptable	"Error Code"[CR]

#### 8.10.6 CF\_AUTOSETUP Command

Command	"CF_AUTOSETUP_%1"[CR]	
%1	"START" ----- Execute Auto Setup	
Details	Execute Auto Setup Note) CF commands does not execute while Auto setup is in process. If the command is sent during this, projector returns error code "302"	
Response	Acceptable	"000"[CR]
	Unacceptable	"Error Code"[CR]

#### 8.10.7 CF\_BACKGND Command

Command	"CF_BACKGND_%1" [CR]	
%1	"BLUE" ----- Select Blue Back "USER" ----- Select User "BLACK" ----- Select Black Back "UP" ----- Switch forward (Blue Back→User→Black Back→Blue Back) "DN" ----- Switch backward (Blue Back→Black Back→User→Blue Back)	
Details	Set Screen status for no signal. (Available only in the normal Power ON status) The status set by this command is stored in EEPROM and the setting remains even after the power is turned to ALL OFF status. *When %1="USER" is received, error code "101" is returned, in the case of Capture non-practice.	
Response	Acceptable	"000" [CR]
	Unacceptable	"Error Code" [CR]



### 8.10.10 CF\_CEIL Command

Command	"CF_CEIL_%1"[CR]	
%1	"ON" ----- Set Ceiling to ON "OFF" ----- Set Ceiling to OFF	
Details	Set/Cancel Ceiling setting. The value set by this command is stored in EEPROM and its setting is effective even after ALL is OFF This command is available in normal Power ON status.	
Response	Acceptable	"000"[CR]
	Unacceptable	"Error Code"[CR]

### 8.10.11 CF\_REAR Command

Command	"CF_REAR_%1"[CR]	
%1	"ON" ----- Set Rear to ON "OFF" ----- Set Rear to OFF	
Details	Set/Cancel Rear setting. When Rear is ON, image is left/right reversed. The status set by this command is stored in EEPROM and its setting is effective after ALL is OFF This command is available in normal Power ON status.	
Response	Acceptable	"000"[CR]
	Unacceptable	"Error Code"[CR]

### 8.10.12 CF\_TERMINAL Command

Command	"CF_TERMINAL_%1"[CR]	
%1	"COMPUTER" -----Set Input mode "MONITOR" ----- Set Monitor Out mode	
Details	Set Terminal setup. This command is available in normal Power ON status. Terminal means Computer 2 in this model.	
Response	Acceptable	"000"[CR]
	Unacceptable	"Error Code"[CR] When Input is Computer 2, the projector returns "101" and the command is not executed.

### 8.10.13 CF\_STANDBYMODE Command

Command	"CF_STANDBYMODE_%1"[CR]	
%1	"ECO" ----- Less standby electricity "NORMAL" ----- Normal standby electricity	
Details	Switch Standby Mode setting. This command is available in normal Power ON status.	
Response	Acceptable	"000"[CR]
	Unacceptable	"Error Code"[CR]





**8.10.21 CF\_KEYDIS Command**

Command	"CF_KEYDIS_%1"[CR]	
%1	"NONE" ----- RC & Projector keys are valid (All are valid) "RC" ----- RC keys are invalid "KEY" ----- Projector keys are invalid	
Details	Disable RC/Projector keys This command is available in normal Power ON status.	
Response	Acceptable	"000"[CR]
	Unacceptable	"Error Code"[CR]

**8.10.22 CF\_PJPINCODE Command**

Command	"CF_PJPINCODE_%1"[CR]	
%1	"0000" – "9999" -----Set PJ PIN CODE directly	
Details	Set PJ PIN CODE to release PJ LOCK. PIN CODE cannot be changed by this command.  -When PJ LOCK is in operation PIN CODE is correct ----- Command is valid (Acceptable) PIN CODE is incorrect ----- Command is invalid(Error Code"102") PIN CODE is out of %1 range ----- Command is invalid (Error Code "? ")  -When PJ LOCK is not in operation PIN CODE is within %1 range ----- Command is valid (Acceptable) PIN CODE is out of %1 range ----- Command is invalid (Error Code "? ")  This command is valid during a dialog "PJ PIN CODE" is displayed after Power On and Count down. Also when PJ LOCK setting is "On1", it is necessary to transmit this command every time lamp turns on.	
Response	Acceptable	"000"[CR]
	Unacceptable	"Error Code"[CR]

**8.10.23 CF\_FANMODE Command**

Command	"CF_FANMODE_%1"[CR]	
%1	"L1" ----- Set Fan Mode to L1 "L2" ----- Set Fan Mode to L2	
Details	Switch Fan Mode When L1 is selected, fan noise after POWER OFF is louder. When L2 is selected, fan noise after POWER OFF becomes quiet, however, fan rotates longer than L1. The status set by this command is stored in EEPROM and its setting is effective even after ALL is OFF. This command is available in normal Power ON status.	
Response	Acceptable	"000"[CR]
	Unacceptable	"Error Code"[CR]

### 8.10.24 CF\_FANCONTROL Command

Command	"CF_FANCONTROL_%1"[CR]	
%1	"OFF" ----- Set Fan control to Off "ON1" ----- Set Fan control to On1 "ON2" ----- Set Fan control to On2	
Details	Set Fan control setting. The status set by this command is stored in EEPROM and its setting is effective even after ALL is OFF. This command is available in normal Power ON status.	
Response	Acceptable	"000"[CR]
	Unacceptable	"Error Code"[CR]

### 8.10.25 CF\_DELAYCTRL Command

Command	"CF_DELAYCTRL_%1"[CR]	
%1	"ON" ----- Set Video delay control On "OFF" ----- Set Video delay control Off	
Details	Set Video delay control. The status set by this command is stored in EEPROM and its setting is effective even after ALL is OFF. This command is available in normal Power ON status.	
Response	Acceptable	"000"[CR]
	Unacceptable	"Error Code"[CR]

### 8.10.26 CF\_CCAPTIONDISP Command

Command	"CF_CCAPTIONDISP_%1"[CR]	
%1	"OFF" ----- Select Off "CC1" ----- Select CC1 "CC2" ----- Select CC2 "CC3" ----- Select CC3 "CC4" ----- Select CC4	
Details	Select channel of Closed caption. The status set with this command is stored in EEPROM and its setting is effective even after ALL is OFF. This command is available in normal Power ON status. Closed caption is available under conditions below; Entered signal is appropriate (Video, NTSC signal of S-video) and System is fixed to NTSC i.	
Response	Acceptable	"000"[CR]
	Unacceptable	"Error Code"[CR]

### 8.10.27 CF\_CCAPTIONCOLOR Command

Command	"CF_CCAPTIONCOLOR_%1"[CR]	
%1	"COLOR" ----- Select Color "WHITE" ----- Select White	
Details	Select color of Closed caption. The status set with this command is stored in EEPROM and its setting is effective even after ALL is OFF. This command is available in normal Power ON status. Closed caption is available under conditions below; Entered signal is appropriate (Video, NTSC signal of S-video) and System is fixed to NTSC.	
Response	Acceptable	"000"[CR]
	Unacceptable	"Error Code"[CR]

### 8.10.28 CF\_FILTERTIMER Command

Command	"CF_FILTERTIMER_%1"[CR]	
%1	"100" ----- Set 100 hours "200" ----- Set 200 hours "300" ----- Set 300 hours "OFF" ----- No warning display "UP" ----- Switch Filter timer forward (Off → 100 → 200 → 300 → Off) "DN" ----- Switch Filter timer backward (Off → 300 → 200 → 100 → Off)	
Details	Set timer of Filter replacement /clean-up warning display.	
Response	Acceptable	"000"[CR]
	Unacceptable	"Error Code"[CR]

### 8.10.29 CF\_FILH Command

Command	"CF_FILH_%1"[CR]	
%1	"RST" -----Reset Filter used time	
Details	Reset filter used time	
Response	Acceptable	"000"[CR]
	Unacceptable	"Error Code"[CR]

### 8.10.30 CF\_FDEFAULT Command

Command	"CF_FDEFAULT_%1"[CR]	
%1	"RST"	
Details	Set the value to Factory Default This command is available in normal Power ON status.	
Response	Acceptable	"000"[CR]
	Unacceptable	"Error Code"[CR]

## 8.11 Other Command

### 8.11.1 CF\_KEYENU Command

Command	"CF_KEYENU_%1"[CR]	
%1	"RIGHT" ----- Shift Pointer on OSD Menu to right "LEFT" ----- Shift Pointer on OSD Menu to left "UP" ----- Shift Pointer on OSD Menu to right "DN" ----- Shift Pointer on OSD Menu to right "SELECT" ----- Behave the same as Select key "AUTOPC" ----- Execute Auto PC adj	
Details	This command behave the same as corresponding keys of Remote Control / Projector Auto PC adj. keeps operating even though projector receives this command again while Auto PC adj. is in process.	
Response	Acceptable	"000"[CR]
	Unacceptable	"Error Code"[CR]

### 8.11.2 CF\_MENU Command

Command	"CF_MENU_%1"[CR]	
%1	"ON" ----- Display OSD Menu "OFF" ----- Cancel OSD menu	
Details	Display / Cancel On Screen Display Menu This command is available in normal Power ON status.	
Response	Acceptable	"000"[CR]
	Unacceptable	"Error Code"[CR]

### 8.11.3 CF\_POWER Command

Command	"CF_POWER_%1"[CR]	
%1	"ON" -----Power ON projector "OFF" ----- Power OFF Projector  Note1) Countdown can be terminated by sending this command.  Note2) Projector returns error code due to unable of command execution depends on its condition.  Note3) Although projector returns "OK", operation may not be proceeding properly. (e.g. After returning "000" for Power ON command, projector gets abnormal temperature.) Use Status read command to get projector states.	
Details	Power ON / OFF projector.	
Response	Acceptable	"000"[CR]
	Unacceptable	"Error Code"[CR]

#### 8.11.4 CF\_FREEZE Command

Command	"CF_FREEZE_%1"[CR]	
%1	"ON" ----- Set Freeze to ON "OFF" ----- Set Freeze to OFF "UP" ----- Switch setting (On → Off → On → ...) "DN" ----- Switch setting (On → Off → On → ...) Note) "UP" and "DN" behave the same.	
Details	Set/Cancel Freeze setting. Although projector returns "000", receiving another Freeze command does not release Freeze operation. This command is available in normal Power ON status.	
Response	Acceptable	"000"[CR]
	Unacceptable	"Error Code"[CR]

#### 8.11.5 CF\_VMUTE Command

Command	"CF_VMUTE_%1"[CR]	
%1	"ON" ----- Set No show ON "OFF" ----- Set No show OFF "UP" ----- Switch setting (On → Off → On → ...) "DN" ----- Switch setting (On → Off → On → ...) Note) "UP" and "DN" behave the same.	
Details	Set/Cancel No show setting. This command is available in normal Power ON status.	
Response	Acceptable	"000"[CR]
	Unacceptable	"Error Code"[CR]

## 9. Status Read Command

### 9.1 Format

- 1) PC issues commands in format as below:

**“CR\_Command” [CR]**

Command : Character Line

- 2) When projector receives the appropriate command, it returns a character line as the required data

**“000\_”%1 [CR]**

%1: Required Data (Character Line. See [Basic Status Read Command Table])

- 3) When the received data cannot be decoded, the projector returns “?”[CR]

### 9.2 Transfer Example

Get total dots of projector by Expand Commands

PC → PJ: “CR\_TDOTS” [CR]

PC ← PJ: “000\_1344” [CR]

### 9.3 Operation Condition

- 1) Basically Status Read Commands should be always operated.
- 2) When Eco mode is selected in Standby mode of Setting menu and projector is in Standby, Status Read Commands are invalid.

## 9.4 Image Status Read Command

### 9.4.1 CR\_BRIGHT Command

Command	"CR_BRIGHT"[CR]	
Details	Get Brightness value of user control	
Response	Acceptable	"000_% a"[CR]
	%a	"000"~"063"
	Unacceptable	"Error Code"[CR]

### 9.4.2 CR\_CONT Command

Command	"CR_CONT"[CR]	
Details	Get Contrast value of user control	
Response	Acceptable	"000_% a"[CR]
	%a	"000"~"063"
	Unacceptable	"Error Code"[CR]

### 9.4.3 CR\_COLOR Command

Command	"CR_COLOR"[CR]	
Details	Get Color value of user control	
Response	Acceptable	"000_%a"[CR]
	%a	"000"~"063"
	Unacceptable	"Error Code"[CR]

### 9.4.4 CR\_TINT Command

Command	"CR_TINT"[CR]	
Details	Get Tint value of user control	
Response	Acceptable	"000_%a"[CR]
	%a	"000"~"063"
	Unacceptable	"Error Code"[CR]

### 9.4.5 CR\_SHARP Command

Command	"CR_SHARP"[CR]	
Details	Get Sharpness value of user control	
Response	Acceptable	"000_%a"[CR]
	%a	"000"~"015"
	Unacceptable	"Error Code"[CR]

### 9.4.6 CR\_GAMMA Command

Command	"CR_GAMMA"[CR]	
Details	Get Gamma value of user control	
Response	Acceptable	"000_%a"[CR]
	%a	"000"~"015"

	Unacceptable	"Error Code"[CR]
--	--------------	------------------

**9.4.7 CR\_WBAL – R Command**

Command	"CR_WBAL-R"[CR]	
Details	Get White Balance Red value of user control	
Response	Acceptable	"000_%a"[CR]
	%a	"000"~"063"
	Unacceptable	"Error Code"[CR]

**9.4.8 CR\_WBAL – G Command**

Command	"CR_WBAL-G"[CR]	
Details	Get White Balance Green value of user control	
Response	Acceptable	"000_%a"[CR]
	%a	"000"~"063"
	Unacceptable	"Error Code"[CR]

**9.4.9 CR\_WBAL – B Command**

Command	"CR_WBAL-B"[CR]	
Details	Get White Balance Blue value of user control	
Response	Acceptable	"000_%a"[CR]
	%a	"000"~"063"
	Unacceptable	"Error Code"[CR]

**9.4.10 CR\_COLTEMP Command**

Command	"CR_COLTEMP"[CR]	
Details	Get Color Temp. setting value	
Response	Acceptable	"000_%a"[CR]
	%a	"000" ----- Xlow "001" ----- Low "002" ----- Mid "003" ----- High "BLACK" ----- Blackboard(Green) mode selected "COLOR" ----- Colorboard selected "BLANK" ----- White Balance has been changed
	Unacceptable	"Error Code"[CR]

**9.4.11 CR\_NZRED Command**

Command	"CR_NZRED"[CR]	
Details	Get setting status of Noise Reduction	
Response	Acceptable	"000_%1"[CR]
	%1	"L1" ----- Noise Reduction for moving image "L2" ----- Noise Reduction for still image "OFF" ----- Noise Reduction is OFF
	Unacceptable	"Error Code"[CR]

### 9.4.12 CR\_PROGV Command

Command	"CR_PROGV"[CR]	
Details	Get setting status of Progressive scan	
Response	Acceptable	"000_%a"[CR]
	%a	"L1" ----- Progressive Mode L1 is selected "L2" ----- Progressive Mode L2 is selected "FILM" ----- Progressive Model FILM is selected "OFF" ----- Progressive scan is disabled
	Unacceptable	"Error Code"[CR]

### 9.4.13 CR\_IMAGE Command

Command	"CR_IMAGE"[CR]	
Details	Get image setting status Required data "CUSTOM1" to "CUSTOM4" is the same as "Image1" to "Image4" displayed when selecting IMAGE on OSD menu	
Response	Acceptable	"000_%a"[CR]
	%a	"DYNAMIC" ----- Dynamic "STAND" ----- Standard "REAL" ----- Real "CINEMA" ----- Cinema "BLACKBOARD" ----- Blackboard "COLORBOARD" ----- Colorboard "CUSTOM1"~"CUSTOM4" ----- Image1~4
	Unacceptable	"Error Code"[CR] --- When the command is invalid due to condition such as Input source

### 9.4.14 CR\_COLBOARD Command

Command	"CR_COLBOARD_%1"[CR]	
Details	Get Colorboard setting status	
Response	Acceptable	"000_%a"[CR]
	%a	"RED" ----- Select Red "BLUE" ----- Select Blue "YELLOW" ----- Select Yellow "GREEN" ----- Select Green
	Unacceptable	"Error Code"[CR]

### 9.4.15 CR\_IMGGMD Command

Command	"CR_IMGGMD"[CR]	
Details	Get Image Gamma setting status	
Response	Acceptable	"000_%a"[CR]
	%a	"DYN" ----- Dynamic "STD" ----- Standard "REL" ----- Real "CNM" ----- Cinema "BKB" ----- Blackboard "CLB" ----- Colorboard
	Unacceptable	"Error Code"[CR]



## 9.5 PC Adjust Status Read Command

### 9.5.1 CR\_FSYNC Command

Command	"CR_FSYNC"[CR]	
Details	Get Fine Sync value	
Response	Acceptable	"000_%a"[CR]
	%a	"0000"~"0031"
	Unacceptable	"Error Code"[CR]

### 9.5.2 CR\_TDOTS Command

Command	"CR_TDOTS"[CR]	
Details	Get Total Dots value	
Response	Acceptable	"000_%a"[CR]
	%a	"nnnn"~"mmmm" (nnnn = Display Dots + Horizontal Position) (mmmm= Maximum value depends on input signal)
	Unacceptable	"Error Code"[CR]

### 9.5.3 CR\_CLAMP Command

Command	"CR_CLAMP"[CR]	
Details	Get Clamp value	
Response	Acceptable	"000_%a"[CR]
	%a	"0001"~"nnnn" (“nnnn” depends on input signal)
	Unacceptable	"Error Code"[CR]

### 9.5.4 CR\_H – POS Command

Command	"CR_H - POS"[CR]	
Details	Get Horizontal Position value	
Response	Acceptable	"000_%a"[CR]
	%a	"0000"~"nnnn" (nnnn = Total Dots - Display Dots)
	Unacceptable	"Error Code"[CR]

### 9.5.5 CR\_V – POS Command

Command	"CR_V - POS"[CR]	
Details	Get Vertical Position value	
Response	Acceptable	"000_%a"[CR]
	%a	"0000"~"nnnn" (nnnn = Total Line - Display Line)
	Unacceptable	"Error Code"[CR]

### 9.5.6 CR\_DDOTS Command

Command	"CR_DDOTS"[CR]	
Details	Get Display Dots value	
Response	Acceptable	"000_%a"[CR]
	%a	"0256"~"nnnn" (nnnn = Total Dots – Horizontal Position value)
	Unacceptable	"Error Code"[CR]

### 9.5.7 CR\_DLINE Command

Command	"CR_DLINE"[CR]	
Details	Get Display Line value	
Response	Acceptable	"000_%a"[CR]
	%a	"0100"~"nnnn" (nnnn = Total Line – Vertical Position value)
	Unacceptable	"Error Code"[CR]

### 9.5.8 CR\_PCSTORE Command

Command	"CR_PCSTORE"[CR]	
Details	Get Free/Stored status of MODE1 - MODE5 for PC Adjust. Each data consists of 10 bytes. Each byte indicates the status of MODE1~MODE10 respectively. (F:Free S:Stored)	
Response	Acceptable	"000_%a"[CR]
	%a	"FFFFFFFF" ----- All Free "SFFFFFFFF" ----- MODE1 is Stored, others are Free : "FFFFFFFFS" ----- MODE5 is Stored, others are Free "SSSSSSSSSS" ----- All Stored
	Unacceptable	"Error Code"[CR]

## 9.6 Video Status Read Command

### 9.6.1 CR\_SERSYS Command

Command	"CR_SERSYS"[CR]	
Details	Get currently selected signal Returns auto-detected signal in Auto mode Only available for Video input. (N/A when Input is computer)	
Response	Acceptable	"000_%a"[CR]
	%a	"1080I60" ----- 1080i 60Hz "1080I50" ----- 1080i 50Hz "1035I" ----- 1035i "720P" ----- 720p "575P" ----- 575p "480P" ----- 480p "575I" ----- 575i (includes Composite signal such as PAL) "480I" ----- 480i (includes Composite signal such as NTSC) "NO_SIGNAL" ----- There is no signal
	Unacceptable	"Error Code"[CR]

## 9.7 Input Status Read Command

### 9.7.1 CR\_INPUT Command

Command	"CR_INPUT"[CR]	
Details	Get selected INPUT No.	
Response	Acceptable	"000_%1"[CR]
	Request data	"1"-3"
	Unacceptable	"Error Code"[CR]

### 9.7.2 CR\_SOURCE Command

Command	"CR_SOURCE"[CR]	
Details	Get selected Source	
Response	Acceptable	"000_%1"[CR]
	Request data	"ANALOG" ----- Analog (RGB) Input is selected "SCART" ----- SCART is selected "VIDEO" ----- Video Input is selected "S-VIDEO" ----- S-Video Input is selected "YPBPR" ----- Component Input is selected
	Unacceptable	"Error Code"[CR]

### 9.7.3 CR\_SRCINP1 Command

Command	"CR_SRCINP1" [CR]	
Details	Get selected source of Input 1_CMP1	
Response	Acceptable	"000_%1"[CR]
	Request data	"ANALOG" ----- Analog RGB Input is selected "YPBPR" ----- YPBPR Input is selected "S-VIDEO" ----- S-Video Input is selected "SCART" ----- Scart Input is selected
	Unacceptable	"Error Code"[CR]

### 9.7.4 CR\_SRCINP2 Command

Command	"CR_SRCINP2" [CR]	
Details	Get selected source of Input 2_CMP2	
Response	Acceptable	"000_%1"[CR]
	Request data	"ANALOG" ----- Analog RGB Input is selected "OUT" ----- Monitor out is selected
	Unacceptable	"Error Code"[CR]

### 9.7.5 CR\_SRCINP3 Command

Command	"CR_SRCINP3" [CR]	
Details	Get selected source of Input 3_Video	
Response	Acceptable	"000_%1"[CR]
	Request data	"VIDEO" ----- Composite Video Input is selected
	Unacceptable	"Error Code"[CR]

**9.7.6 CR\_SYSTEM Command**

Command	"CR_SYSTEM"[CR]	
Details	Get selected System	
Response	Acceptable	"000_%1"[CR] "VGA1" ----- VGA1 is selected "VGA2" ----- VGA2 is selected : "XGA1"----- XGA1 is selected : "WXGA3" ----- WXGA3 is selected "1080i" ----- 1080i is selected "1035i" ----- 1035i is selected "720p" ----- 720p is selected "575p" ----- 575p is selected "480p" ----- 480p is selected "575i" ----- 575i is selected "480i" ----- 480i is selected "MODE1" ----- Mode1 is selected : "MODE10" ----- Mode10 is selected When there is no signal, projector returns error code"101" [CR]
	%1	Input is PC Analog "AUTO" ----- Auto is selected "1080i" -----1080i is selected "1035i" ----- 1035i is selected "720p" ----- 720p is selected "575p" ----- 575p is selected "480p" ----- 480p is selected "575i" ----- 575i is selected "480i" ----- 480i is selected Projector returns selected System status regardless of the signal input.
		Input is Y,Pb/Cb,Pr /Cr "AUTO" ----- Auto is selected "NTSC" ----- NTSC is selected "NTSC443" ----- NTSC4.43 is selected "PAL" ----- PAL is selected "SECAM" ----- SECAM is selected "PAL - M" ----- PAL-M is selected "PAL - N" ----- AL-N is selected Projector returns selected System status regardless of the signal input.
	Unacceptable	"Error Code"[CR]

**9.7.7 CR\_SYSLIST Command**

Command	"CR_SYSLIST"[CR]	
Details	Get selectable System titles	
Response	Acceptable	"000_%1_%2_..._%x" [CR]
	%1	<p>- When Input is PC-Analog                      "XGA1" ----- XGA1 is selectable                      "1080i" ----- 1080i is selectable                      Projector does not return Auto, Mode1-10                      When there is no signal, it returns Error Code "101"</p> <p>-When Input is Y,Pb/Cb,Pr/Cr                      Returns all the System titles on Menu including Auto                      "AUTO" ----- Auto is selectable                      "1080i" ----- 1080i is selectable                      "1035i" ----- 1035i is selectable                      :                      :                      "575i" ----- 575i is selectable                      "480i" ----- 480i is selectable                      Projector does not return Error Code "101" even if there is no signal.</p> <p>-When Input is Video, S-Video                      Returns all the System titles on Menu including Auto                      "AUTO" -----Auto is selectable                      "PAL" ----- PAL is selectable                      "SECAM" ----- SECAM is selectable                      :                      :                      "PAL-N" ----- SECAM is selectable                      Projector does not return Error Code "101" even if there is no signal.</p>
	Unacceptable	"Error Code"[CR]

**9.7.8 CR\_MODELIST Command**

Command	"CR_MODELIST"[CR]	
Details	Get selectable Mode titles	
Response	Acceptable	"000_%1_%2_..._%x" [CR]
	%1 %2 : %x	<p>Returns Error code "101" when Input is other than PC-Analog                      Returns Error code "101" when Input is PC-Analog but no signal                      When Input is PC-Analog and signal is found, returns selectable Mode among Mode1 – 10</p> <p>"MODE1"                      :                      :                      "MODE10"</p>
	Unacceptable	"Error Code"[CR]

## 9.8 Screen Status Read Command

### 9.8.1 CR\_SCREEN Command

Command	"CR_SCREEN"[CR]		
Details	Get selected on-screen image size		
Response	Acceptable	"000_%a"[CR]	
	%a	Input is PC	"NORMAL" ----- Normal mode is selected "TRUE" ----- True mode is selected "WIDE" ----- Wide mode is selected "FULL" ----- Full mode is selected "CUSTOM" ----- Custom mode is selected When the screen is set to D.Zoom, projector returns the previous status (NORMAL)
		Input is Video	"NORMAL" ----- Normal mode is selected "WIDE" ----- Wide is selected "CUSTOM" ----- Custom size is selected
	Unacceptable	"Error Code"[CR]	

### 9.8.2 CR\_KYSTNMODE Command

Command	"CR_KYSTNMODE"[CR]	
Details	Get setting status of Keystone Store Mode	
Response	Acceptable	"000_%a"[CR]
	%a	"STR" ----- Store mode is "Store" "RST" ----- Store mode is "Reset"
	Unacceptable	"Error Code"[CR]

### 9.8.3 CR\_VSCALE Command

Command	"CR_VSCALE"[CR]	
Details	Get setting status of Vertical Scale Store Mode	
Response	Acceptable	"000_%1[CR]
	%1	"-32" ~ "032"
	Unacceptable	"Error Code"[CR]

### 9.8.4 CR\_VPOS Command

Command	"CR_VPOS"[CR]	
Details	Get setting status of Vertical Position Store Mode	
Response	Acceptable	"000_%1"[CR]
	%1	"-15" ~ "015"
	Unacceptable	"Error Code"[CR]

### 9.8.5 CR\_HSCALE Command

Command	"CR_HSCALE"[CR]	
Details	Get setting status of Horizontal Scale Store Mode	
Response	Acceptable	"000_%1"[CR]
	%1	"-32" ~ "032"
	Unacceptable	"Error Code"[CR]

**9.8.6 CR\_HPOS Command**

Command	"CR_HPOS"[CR]	
Details	Get setting status of Horizontal Position Store Mode	
Response	Acceptable	"000_%1"[CR]
	%1	"-15" ~ "015"
	Unacceptable	"Error Code"[CR]

## 9.9 Lamp Status Read Command

### 9.9.1 CR\_LAMPREPL Command

Command	"CR_LAMPREPL"[CR]	
Details	Get information of Lamp Replacement time	
Response	Acceptable	"000_%1"[CR]
	%1	"1Y" ----- Over lamp replacement time "1N" ----- Within lamp replacement time  "1" means the number of lamps. (1 lamp model→ "1") "Y"/"N" means if it has reached its replacement time or not. e.g. "1Y" -----projector is 1 lamp model and Lamp is over its replacement time
	Unacceptable	"Error Code"[CR]

### 9.9.2 CR\_LAMPH Command

Command	"CR_LAMPH"[CR]	
Details	Get total running time of lamp by hour (h) *Actual running time, not corresponding value	
Response	Acceptable	"000_%1"[CR]
	%1	"00000"~"99999"
	Unacceptable	"Error Code"[CR]

### 9.9.3 CR\_LAMPCORRESPH Command

Command	"CR_LAMPCORRESPH"[CR]	
Details	Get total running time of lamp by hour (h) * Corresponding value, not actual running time	
Response	Acceptable	"000_%1"[CR]
	%1	"00000"~"99999"
	Unacceptable	"Error Code"[CR]

### 9.9.4 CR\_LAMPMODE Command

Command	"CR_LAMPMODE"[CR]	
Details	Get setting status of Lamp Mode	
Response	Acceptable	"000_%1"[CR]
	%1	"HIGH" ----- Lamp Mode is High "NORMAL" ----- Lamp Mode is Normal "ECO" ----- Lamp Mode is Eco
	Unacceptable	"Error Code"[CR]

### 9.9.5 CR\_LAMPSTS Command

Command	"CR_LAMPSTS"[CR]	
Details	Get Lighting status of lamp	
Response	Acceptable	"000_%1"[CR]
	%1	<p>"n****" A number of * should be among 1-4.                      First character shows how many lamps are incorporated in projector. (1,2 or 4 )</p> <p>Second character shows following status in order of lamp number.                      "I" Lamp is ON                      "O" Lamp is OFF                      "X" Lamp failure</p> <p>e.g.                      "1I" ..... 1 lamp model and Lamp is ON                      "2IO..... 2 lamps model and No.1 Lamp is ON and No.2Lamp is OFF                      "4IOXI" .... 4 lamps model and No.1,No.4 lamps are ON. No.2 lamp is OFF and No.3 model is failed.</p>
	Unacceptable	"Error Code"[CR]

### 9.9.6 CR\_PROJH Command

Command	"CR_PROJH"[CR]	
Details	Get total running time of Projector by hour (h)	
Response	Acceptable	"000_%1"[CR]
	%1	"0000000"~"0099999"
	Unacceptable	"Error Code"[CR]

### 9.9.7 CR\_HMLAMP Command

Command	"CR_HMLAMP"[CR]	
Details	Get lamp number.	
Response	Acceptable	"000_%1"[CR]
	%1	"001"
	Unacceptable	"Error Code" [CR]

## 9.10 Sound Status Read Command

### 9.10.1 CR\_VOLUME Command

Command	"CR_VOLUME"[CR]	
Details	Get Volume value of user control	
Response	Acceptable	"000_%a"[CR]
	%a	"000"~"031"
	Unacceptable	"Error Code" [CR]

### 9.10.2 CR\_MUTE Command

Command	"CR_MUTE"[CR]	
Details	Get sound mute setting status	
Response	Acceptable	"000_%a"[CR]
	%a	"ON" ----- Sound Mute is ON "OFF" ----- Sound Mute is OFF
	Unacceptable	"Error Code" [CR]

## 9.11 Setting Status Read Command

### 9.11.1 CR\_LANG Command

Command	"CR_LANG"[CR]	
Details	Get selected language	
Response	Acceptable	"000_%a"[CR]
	%a	"ENG" ----- English is selected "DEU" ----- German is selected "FRA" ----- French is selected "ITA" ----- Italian is selected "ESP" ----- Spanish is selected "POR" ----- Portuguese is selected "NED" ----- Dutch is selected "SVE" ----- Swedish is selected "JPN" ----- Japanese is selected "CHI" ----- Chinese is selected "KOR" ----- Korean is selected "RUS" ----- Russian is selected "FIN" ----- Finnish is selected "POL" ----- Polish is selected "HUN" ----- Hungarian is selected "ROM" ----- Romanian is selected "THA" ----- Thai is selected "TUR" ----- Turkish is selected "KAZ" ----- Kazakh is selected. "VIE" ----- Vietnamese is selected
	Unacceptable	"Error Code"[CR]

### 9.11.2 CR\_INPUTSEARCH Command

Command	"CR_INPUTSEARCH"[CR]	
Details	Get setting status of Input search	
Response	Acceptable	"000_%a"[CR]
	%a	"OFF" ----- Input search is OFF "ON1" ----- Input search is On1 "ON2" ----- Input search is On2
	Unacceptable	"Error Code"[CR]

### 9.11.3 CR\_AUTOSETUPPCADJ Command

Command	"CR_AUTOSETUPPCADJ" [CR]	
Details	Get Auto PC adj. setting status in Auto setup	
Response	Acceptable	"000_%a"[CR]
	%a	"ON" ----- Auto PC ADJ. in Auto setup is ON "OFF" ----- Auto PC ADJ. in Auto setup is OFF
	Unacceptable	"Error Code"[CR]

### 9.11.4 CR\_AUTOSETUPKEYSTONE Command

Command	"CR_AUTOSETUPKEYSTONE" [CR]	
Details	Get Keystone setting status in Auto setup	
Response	Acceptable	"000_%a"[CR]
	%a	"AUTO" ----- Auto Keystone is Auto "MANUAL" ----- Auto Keystone is Manual "OFF" ----- Auto Keystone is OFF
	Unacceptable	"Error Code"[CR]

	Unacceptable	"Error Code"[CR]
--	--------------	------------------

**9.11.5 CR\_BACKGND Command**

Command	"CR_BACKGND" [CR]	
Details	Get setting status of Screen for no signal	
Response	Acceptable	"000_%1" [CR]
	%1	"BLUE" ----- Blue Back is selected "USER" ----- User is selected "BLACK" ----- Black Back is selected
	Unacceptable	"Error Code" [CR]

**9.11.6 CR\_DISP Command**

Command	"CR_DISP"[CR]	
Details	Get setting status of Display	
Response	Acceptable	"000_%a"[CR]
	%a	"ON" ----- Display is ON "OFF" ----- Display is OFF "CNTDWNOFF" ----- Countdown OFF
	Unacceptable	"?"[CR]

**9.11.7 CR\_LOGO Command**

Command	"CR_LOGO"[CR]	
Details	Get setting status of Logo	
Response	Acceptable	"000_%1"[CR]
	%1	"OFF" ----- Logo function is OFF "DFLT" ----- Default Logo is selected "USER" ----- User Logo is selected
	Unacceptable	"?"[CR]

**9.11.8 CR\_CEIL Command**

Command	"CR_CEIL" [CR]	
Details	Get setting status of Ceiling	
Response	Acceptable	"000_%1"[CR]
	%1	"ON" ----- Ceiling is ON "OFF" ----- Ceiling is OFF
	Unacceptable	"Error Code" [CR]

**9.11.9 CR\_REAR Command**

Command	"CR_REAR" [CR]	
Details	Get setting status of Rear	
Response	Acceptable	"000_%1"[CR]
	%1	"ON" ----- Rear is ON "OFF" ----- Rear is OFF
	Unacceptable	"Error Code" [CR]

**9.11.10 CR\_TERMINAL Command**

Command	"CR_TERMINAL" [CR]	
Details	Get setting status of Terminal	
Response	Acceptable	"000_%a"[CR]
	%a	"COMPUTER"-----Computer Input mode "MONITOR"-----Monitor Out mode
	Unacceptable	"?"[CR]

**9.11.11 CR\_STANDBYMODE Command**

Command	"CR_STANDBYMODE" [CR]	
Details	Get Standby Mode setting status	
Response	Acceptable	"000_%a"[CR]
	%a	"ECO" ----- Eco Mode "NORMAL" ----- Normal Mode
	Unacceptable	"?"[CR]

**9.11.12 CR\_P-MANE Command**

Command	"CR_P-MANE"[CR]	
Details	Get Power management setting status	
Response	Acceptable	"000_%a"[CR]
	%a	"OFF" ----- Power Management is OFF "READY" ----- Power Management is Ready "SHUTDOWN" ---- Power Management is set to Shut Down mode
	Unacceptable	"Error Code" [CR]

**9.11.13 CR\_P-MANETIME Command**

Command	"CR_P-MANETIME"[CR]	
Details	Get time to start Power Management	
Response	Acceptable	"000_%a"[CR]
	%a	"001"~"030" ----- 1 minute to 30 minutes
	Unacceptable	"Error Code" [CR]

**9.11.14 CR\_ON-STA Command**

Command	"CR_ON-STA"[CR]	
Details	Get Direct On setting status	
Response	Acceptable	"000_%a"[CR]
	%a	"ON" ----- Direct On Start is ON "OFF" ----- Direct On Start is OFF
	Unacceptable	"Error Code" [CR]

**9.11.15 CR\_PTIMEMODE Command**

Command	"CR_PTIMEMODE"[CR]	
Details	Get operation mode of P-timer.	
Response	Acceptable	"000_%a"[CR]
	%a	"COUNTUP" ----- Count up is selected "COUNTDN" ----- Count down is selected.
	Unacceptable	"Error code"[CR]

**9.11.16 CR\_PTIMER Command**

Command	"CR_PTIMER"[CR]	
Details	Get current status of P-timer	
Response	Acceptable	"000_%a"[CR]
	%a	"ON" ----- P-timer is in execution "STOP" ----- P-timer is paused "OFF" ----- P-timer is inactive
	Unacceptable	"Error code"[CR]

**9.11.17 CR\_PTIME Command**

Command	"CR_PTIME"[CR]	
Details	Get setting status of Countdown timer.	
Response	Acceptable	"000_%a"[CR]
	%a	"001"~"180" -----1~180 minutes
	Unacceptable	"Error code"[CR]

**9.11.18 CR\_RCODE Command**

Command	"CR_RCODE"[CR]	
Details	Get selected Remote Control Code	
Response	Acceptable	"000_%a"[CR]
	%a	"001" ----- Code1 is selected "002" ----- Code2 is selected
	Unacceptable	"Error Code" [CR]

**9.11.19 CR\_SECURITY Command**

Command	"CR_SECURITY" [CR]	
Details	Get Security Mode setting status	
Response	Acceptable	"000_%1[CR]
	%1	"ON" ----- PJ Lock setting on Menu is ON-1 or ON-2 "OFF" -----PJ Lock setting on Menu is OFF
	Unacceptable	"Error Code" [CR]

**9.11.20 CR\_KEYDIS Command**

Command	"CR_KEYDIS"(CR)	
Details	Get disability status of RC/Projector keys (valid or invalid)	
Response	Acceptable	"000_%a"[CR]
	%a	"NONE" ----- RC / Projector keys are valid "RC" ----- RC keys are invalid "KEY" ----- Projector keys are invalid
	Unacceptable	"Error Code" [CR]

**9.11.21 CR\_PJLOCKNOW Command**

Command	"CR_PJLOCKNOW" [CR]	
Details	Get if PJ lock is actually in operation	
Response	Acceptable	"000_%1[CR]
	%1	"LOCK" ----- PJ Lock is in operation. PJ Lock status is ON-1 or ON-2 on Menu, and PJ PIN CODE is not entered so that projector is actually locked. "FREE" ----- PJ Lock is released. PJ Lock status is OFF, or, status is ON-1 or ON-2 on Menu but PJ PIN CODE is entered correctly so that PJ Lock is released.
	Unacceptable	"Error Code" [CR]

**9.11.22 CR\_PJLOCKMENU Command**

Command	"CR_PJLOCKMENU" [CR]	
Details	Get status of PJ Lock on Menu	
Response	Acceptable	"000_%1[CR]
	%1	"ON1" ----- PJ Lock status is On-1 "ON2" ----- PJ Lock status is On-2 "OFF" ----- PJ Lock status is OFF
	Unacceptable	"Error Code" [CR]

**9.11.23 CR\_FANMODE Command**

Command	"CR_FANMODE"[CR]	
Details	Get selected Fan mode	
Response	Acceptable	"000_%a"[CR]
	%a	"L1" ----- Fan mode is L1 "L2" ----- Fan mode is L2
	Unacceptable	"Error Code" [CR]

**9.11.24 CR\_FANCONTROL Command**

Command	"CR_FANCONTROL"[CR]	
Details	Get selected Fan control setting status	
Response	Acceptable	"000_%a"[CR]
	%a	"OFF" ----- Fan control is OFF "ON1" ----- Fan control is ON1 "ON2" ----- Fan control is ON2
	Unacceptable	"Error Code" [CR]

**9.11.25 CR\_DELAYCTRL Command**

Command	"CR_DELAYCTRL"[CR]	
Details	Get setting status of Video delay control	
Response	Acceptable	"000_%1"[CR]
	%1	"ON" ----- Video delay control is active "OFF" ----- Video delay control is inactive
	Unacceptable	"Error Code"[CR]

**9.11.26 CR\_FILH Command**

Command	"CR_FILH"[CR]	
Details	Get Filter used time	
Response	Acceptable	"000_%1"[CR]
	%1	"00000"~"99999" ----- 0 hour to 99999 hours
	Unacceptable	"Error Code"[CR]

**9.11.27 CR\_CCAPTIONDISP Command**

Command	"CR_CCAPTIONDISP"[CR]	
Details	Get selected channel of Closed caption	
Response	Acceptable	"000_%a"[CR]
	%a	"OFF" ----- Off "CC1" ----- CC1 is selected "CC2" ----- CC2 is selected "CC3" ----- CC3 is selected "CC4" ----- CC4 is selected
	Unacceptable	"Error Code"[CR]

**9.11.28 CR\_CCAPTIONCOLOR Command**

Command	"CR_CCAPTIONCOLOR_%1"[CR]	
Details	Get selected color of Closed caption	
Response	Acceptable	"000"[CR]
	%a	"COLOR" ----- Color is selected "WHITE" ----- White is selected
	Unacceptable	"Error Code"[CR]

**9.11.29 CR\_FILREPL Command**

Command	"CR_FILREPL"[CR]	
Details	Get the information of Filter replacement time	
Response	Acceptable	"000_%1"[CR]
	%1	"1Y" ----- Over filter replacement time "1N" ----- Within filter replacement time
	Unacceptable	"Error Code"[CR]

**9.11.30 CR\_FILTER Command**

Command	"CR_FILTER" [CR]	
Details	Get setting time which filter warning OSD is displayed	
Response	Acceptable	"000_%1"[CR]
	%1	"100" ----- 100 hours "200" ----- 200 hours "300" ----- 300 hours "OFF" ----- No OSD display
	Unacceptable	"Error Code"[CR]

## 9.12 Other Status Read Command

### 9.12.1 CR\_STATUS Command

Command	"CR_STATUS"(CR)	
Details	Get status of Projector behavior. This command affects the same as "CR0" of Basic Serial command, but this has an error code.	
Response	Acceptable	"000_%1"[CR]
	%1	"00"= Power ON "80"= Stand by "40"= Count down "20"= Cooling down "10"= Power failure "28"= Cooling down due to abnormal temperature "88"= Stand by after Cooling down "24"= Power saving cooling down "04"= Power saving "21"= Cooling down due to Lamp failure "81"= Stand by after Cooling down due to Lamp failure
	Unacceptable	"Error Code"[CR]

### 9.12.2 CR\_SIGNAL Command

Command	"CR_SIGNAL"(CR)	
Details	Get Signal status if there is signal or not	
Response	Acceptable	"000_%a"[CR]
	%a	"ON" ----- Signal is found "OFF" ----- There is no signal
	Unacceptable	"Error Code" [CR]

### 9.12.3 CR\_VMUTE Command

Command	"CR_VMUTE"[CR]	
Details	Get setting status of No Show	
Response	Acceptable	"000_%a"[CR]
	%a	"ON" ----- No Show is ON, User Logo (My picture) is displayed "OFF" ----- No Show is OFF
	Unacceptable	"Error Code" [CR]

### 9.12.4 CR\_FREEZE Command

Command	"CR_FREEZE"[CR]	
Details	Get setting status of Freeze	
Response	Acceptable	"000_%a"[CR]
	%a	"ON" ----- Freeze is ON "OFF" ----- Freeze is OFF
	Unacceptable	"Error Code" [CR]

### 9.12.5 CR\_TEMPWARN Command

Command	"CR_TEMPWARN"[CR]	
Details	<p>Get the temperature inside a projector and its condition if it is abnormal temperature or close to abnormal temperature                  If there are several sensors installed, it is possible to get information from all the sensors at once.</p>	
Response	Acceptable	"000_%a_%b_%c"[CR]
	%a %b %c	<p>%a ----- Sensor 1 status                  %b ----- Sensor 2 status                  %c ----- Sensor 3 status</p> <p>"W" ---- Approach or reach abnormal temperature                  (dangerous temperature)                  "S" ---- Far from abnormal temperature (safe temperature)                  "N" ---- Sensor detects no abnormal temperature</p> <p>[Example]                  "S_W_S"[CR] means Sensor 1 detects safe temperature, Sensor 2 detects abnormal temperature and Sensor 3 detects safe temperature                  Note) When the temperature difference between Sensor 1 and 3 reaches specific value, some of the models detect it as Abnormal temperature. In this case, the 3rd data shows if the temperature difference between Sensor 1 and 3 is dangerous state or not. The 3rd data means temperature abnormality due to Sensor 3                  When abnormal temperature is not detected by sensor, "N" (No connection with temperature abnormality) is returned.</p>
	Unacceptable	"Error Code" [CR]

### 9.12.6 CR\_TEMP Command

Command	"CR_TEMP"[CR]	
Details	Get current temperature inside a projector. If there are several sensors installed, it is possible to get information from all the sensors at once.	
Response	Acceptable	<p>"000_%1_%2_%3"[CR]</p> <p>%1= Sensor 1 temperature (Outside temperature) %2= Sensor 2 temperature (Inside temperature1) %3= Sensor 3 temperature (Inside temperature2)</p> <p>%1,%2 are consists of 6 bites fixed There must be 1 space between %1 and %2, and, %2 and %3</p> <p>e.g. _31.5F</p> <p>"_" means a space and "-" changes into "-", when temperature gets below freezing.</p> <p>e.g. -05.5F</p> <p>The last character shows if corresponding sensor is under abnormal temperature.</p> <p>"F" ----- Abnormal temperature "W"-----Close to abnormal temperature(Temperature is as high to display Warning) "S" -----Not close to abnormal temperature (Temperature is low enough and safe.) "N"-----Applicable sensor does not detect abnormal temperature "E" -----Not able to return temperature data</p> <p>When several sensors are incorporated, projector returns values continuously. e.g. "_31.5F_35.2S_38.0W"[CR]</p> <p>A data of sensor 1 comes first and a data of sensor 2 follows after 1 space.</p> <p>As described respectively in e.g., sensor 1 detects abnormal temp., sensor 2 detects 35.2 degrees which means safety, and sensor 3 is 38 degrees which is close to abnormal temp. In case projector cannot return its data due to some hard ware failure, the last character becomes "E" such as "_00.0E".</p> <p>Some of the projectors get abnormal temperature because of heat of Lamp ballast in Standby mode or Powering ON. Therefore detection of abnormal temperature is suspended while Standby mode or adequate time after Power ON, and during that time projector returns "_----N" as a temperature data.</p>
	Unacceptable	"Error Code"[CR]

### 9.12.7 CR\_TEMPFAIL Command

Command	"CR_TEMPFAIL"[CR]	
Details	Get the temperature inside a projector when abnormal temperature occurs. If there are several sensors installed, it is possible to get information from all the sensors at once.	
Response	Acceptable	"000_%a_%b_%c"[CR]
	%a %b %c	<p>%a ----- Sensor 1 temp. (External temp.)                      %b ----- Sensor 2 temp. (Internal temp.1)                      %c ----- Sensor 3 temp. (Internal temp.2)</p> <p>[Example]                      "_31.5F"[CR]                      "_" indicates a space. When the temperature sinks to -, the first character is "-" like "-05.5F"[CR]                      The last character means the sensor's status if it reaches abnormal temperature</p> <p>Exceeding critical temp. ----- "F"                      Temp. is safe ----- "S"                      Sensor detects no critical temp.----- "N"</p> <p>The example shows that sensor 1 indicates 31.5 degrees and the temperature is abnormal.                      When the temperature is safe, all data are represented as "□000S".                      When the projector is reset, "□000S" is set, and every time abnormal temperature occurs, it renews the data and returns it.                      In short, it only returns the renewed data of the latest abnormal temperature and the previous data is deleted.</p>
	Unacceptable	"Error Code" [CR]